

Exhaust air module NIBE FLM S45



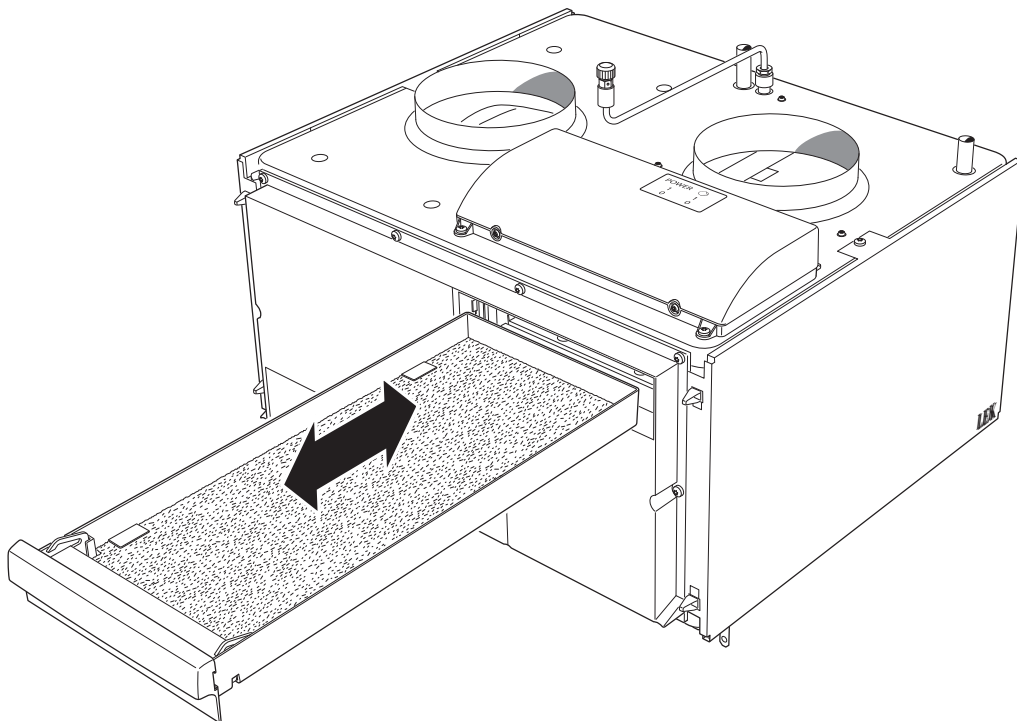
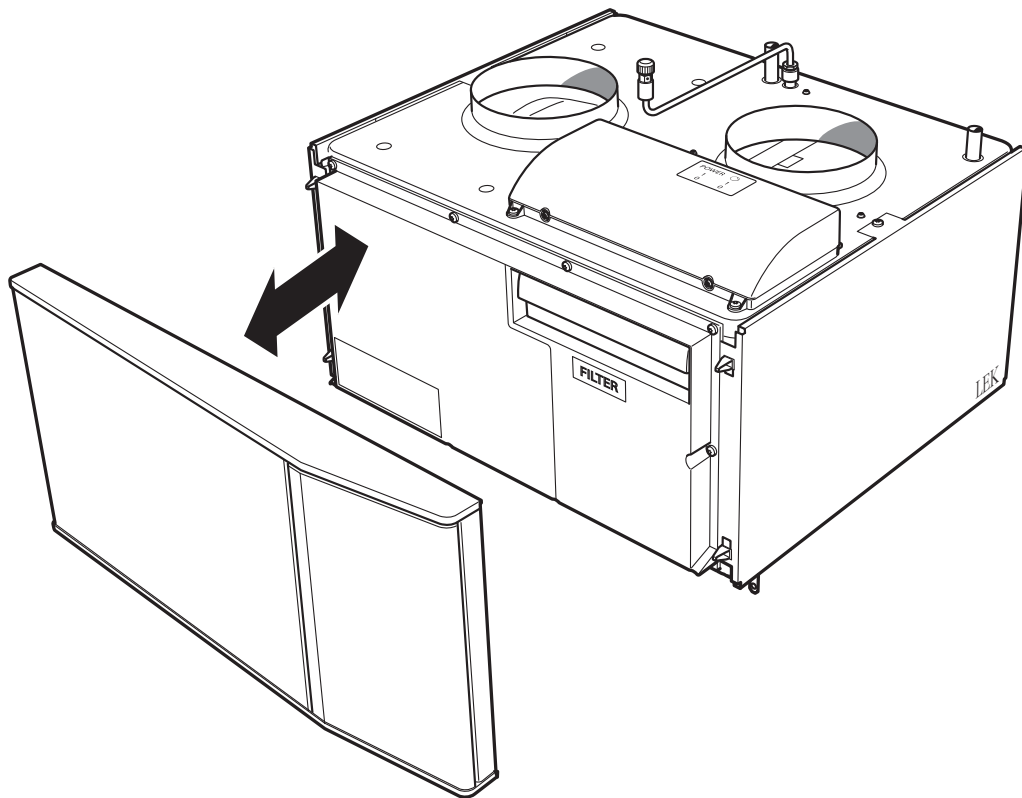

Table of Contents

| | | | | | |
|---|---|----|----|--|----|
| 1 | <i>Important information</i> _____ | 4 | 7 | <i>Program settings</i> _____ | 26 |
| | Safety information _____ | 4 | | Menu system _____ | 26 |
| 2 | <i>Delivery and handling</i> _____ | 7 | 8 | <i>Service</i> _____ | 28 |
| | Transport _____ | 7 | | Service actions _____ | 28 |
| | Assembly _____ | 7 | 9 | <i>Disturbances in comfort</i> _____ | 29 |
| | Supplied components _____ | 8 | | Troubleshooting _____ | 29 |
| | Removing the covers _____ | 8 | 10 | <i>Accessories</i> _____ | 30 |
| 3 | <i>The design of the exhaust air module</i> _____ | 9 | 11 | <i>Technical data</i> _____ | 31 |
| | Pipe connections _____ | 10 | | Dimensions and setting-out coordinates _____ | 31 |
| | HVAC components _____ | 10 | | Technical specifications _____ | 32 |
| | Sensors etc. _____ | 10 | | Electrical circuit diagram _____ | 33 |
| | Electrical components _____ | 10 | | <i>Item register</i> _____ | 35 |
| | Ventilation _____ | 10 | | <i>Contact information</i> _____ | 39 |
| | Miscellaneous _____ | 10 | | | |
| 4 | <i>Pipe and ventilation connections</i> _____ | 11 | | | |
| | General pipe connections _____ | 11 | | | |
| | Dimensions and pipe connections _____ | 12 | | | |
| | Mounting _____ | 12 | | | |
| | Brine side _____ | 13 | | | |
| | Condensation water hose _____ | 14 | | | |
| | General ventilation connection _____ | 15 | | | |
| | Ventilation flow _____ | 15 | | | |
| | Adjusting ventilation _____ | 15 | | | |
| | Dimension and ventilation connections _____ | 15 | | | |
| | Installation alternative _____ | 16 | | | |
| 5 | <i>Electrical connections</i> _____ | 18 | | | |
| | General _____ | 18 | | | |
| | Connections _____ | 18 | | | |
| 6 | <i>Commissioning and adjusting</i> _____ | 22 | | | |
| | Preparations _____ | 22 | | | |
| | Filling and venting _____ | 22 | | | |
| | Start-up and inspection _____ | 23 | | | |

1 Important information

Safety information

This manual describes installation and service procedures for implementation by specialists.

The manual must be left with the customer.

This appliance can be used by children aged from 8 years and above and persons with reduced physical, sensory or mental capabilities or lack of experience and knowledge if they have been given supervision or instruction concerning use of the appliance in a safe way and understand the hazards involved. Children shall not play with the appliance. Cleaning and user maintenance shall not be made by children without supervision.

Rights to make any design or technical modifications are reserved.

©NIBE 2019.

MARKING

CE The CE mark is obligatory for most products sold in the EU, regardless of where they are made.

IP21 Classification of enclosure of electro-technical equipment.



Danger to person or machine.



Read the User Manual.

SYMBOLS



NOTE

This symbol indicates danger to person or machine .



Caution

This symbol indicates important information about what you should consider when installing or servicing the installation.



TIP

This symbol indicates tips on how to facilitate using the product.

SERIAL NUMBER

The serial number can be found at the bottom left inside the front cover.

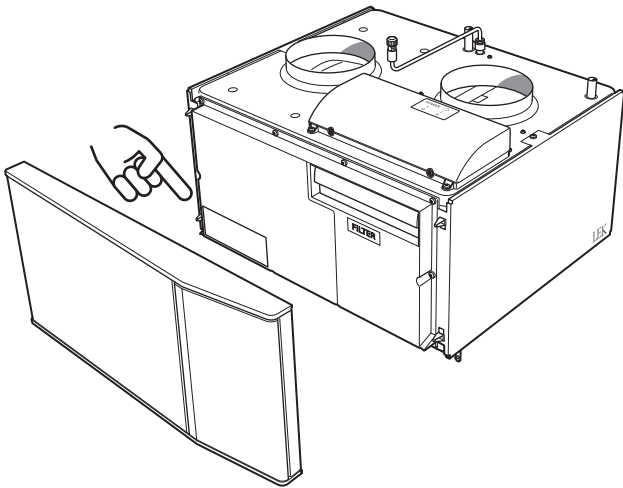

Caution

You need the product's (14 digit) serial number for servicing and support.

RECOVERY



Leave the disposal of the packaging to the installer who installed the product or to special waste stations.

When disposing of the product, its constituent materials and components, e.g. compressors, fans, circulation pumps and circuit boards, must be disposed of at a special waste station or dealer who provides this type of service.

To access the separate components, refer to the section that shows the construction of the product. No special tools are required for access.

Improper disposal of the product by the user results in administrative penalties in accordance with current legislation.

INSPECTION OF THE INSTALLATION

In addition, fill in the page for the installation data in the User Manual.

Current regulations require the heating installation to be inspected before it is commissioned. The inspection must be carried out by a suitably qualified person. Current regulations require the exhaust air module to be inspected before it is commissioned. The inspection must be carried out by a suitably qualified person. In addition, fill in the page for the installation data in the User Manual.

| ✓ | Description | Notes | Signature | Date |
|-------------|--------------------------------------|-------|-----------|------|
| Ventilation | | | | |
| | Setting the ventilation flow | | | |
| Brine | | | | |
| | Non-return valve | | | |
| | System flushed | | | |
| | System vented | | | |
| | Antifreeze | | | |
| | Expansion vessel | | | |
| | Particle filter | | | |
| | Safety valve | | | |
| | Shut off valves | | | |
| | Circulation pump setting | | | |
| | Checking the condensation water seal | | | |
| | Trim valve | | | |
| Electricity | | | | |
| | Connections | | | |
| | Phase voltage | | | |
| | Supply connected 230 V | | | |
| | Circuit fuses | | | |

2 Delivery and handling

Transport

The exhaust air module should be transported and stored in the dry.

Assembly

FLM S45 is installed on top of the ground heat pump or freestanding on brackets. Noise from the circulation pump or fan can be transferred to the brackets.

- Install with its back to an outside wall, ideally in a room where noise does not matter, in order to eliminate noise problems. If this is not possible, avoid placing it against a wall behind a bedroom or other room where noise may be a problem.
- Wherever the unit is located, walls to sound sensitive rooms should be fitted with sound insulation.
- Route pipes so they are not fixed to an internal wall that backs on to a bedroom or living room.

INSTALLATION AREA

Leave a free space of 800 mm in front of the product. Leave free space between FLM S45 and wall/fittings/cables/pipes etc. It is recommended that a space of at least 10 mm is left to reduce the risk of noise and of any vibrations being propagated.

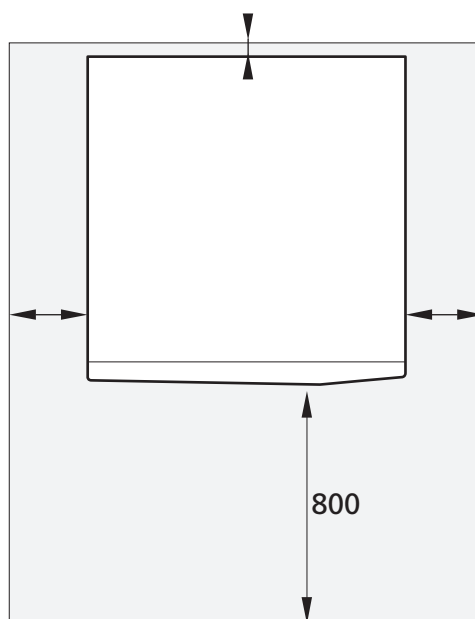

NOTE

Ensure that there is sufficient space (300 mm) above FLM S45 for installing ventilation hoses.

Supplied components

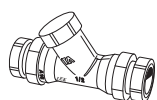

Trim valve (RN1)
Ø 15 mm



Non-return valve (RM1)
Ø 32 mm



Condensation water hose
Ø 20 mm

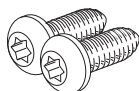

2 x screws (T25) for in-
stalling FLM S45 on NIBE
heat pump

LOCATION

The bag of supplied items is placed on top of FLM S45.

Removing the covers

FRONT COVER

1. Remove the service cover by pulling it straight out.

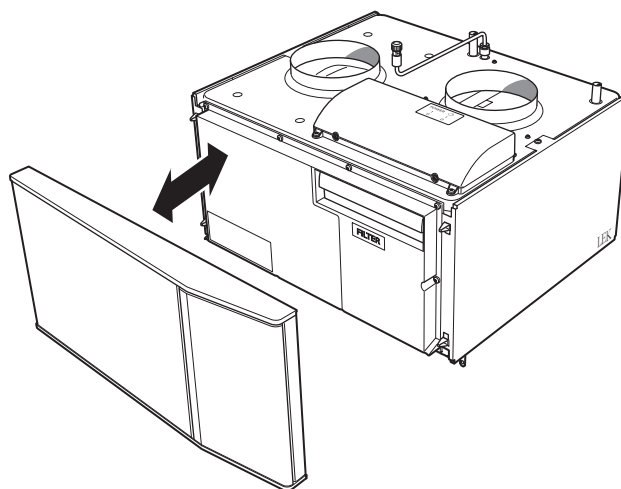

SIDE COVERS

1. Undo the screws at the upper edge.
2. Lift the side hatches upwards and twist the cover outwards slightly.
3. Assembly takes place in the reverse order.

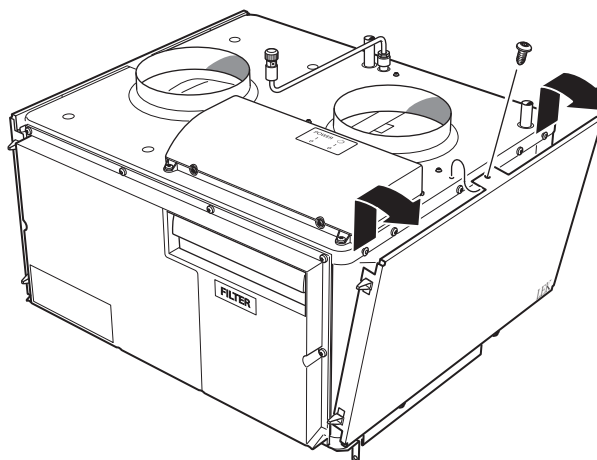

3 The design of the exhaust air module

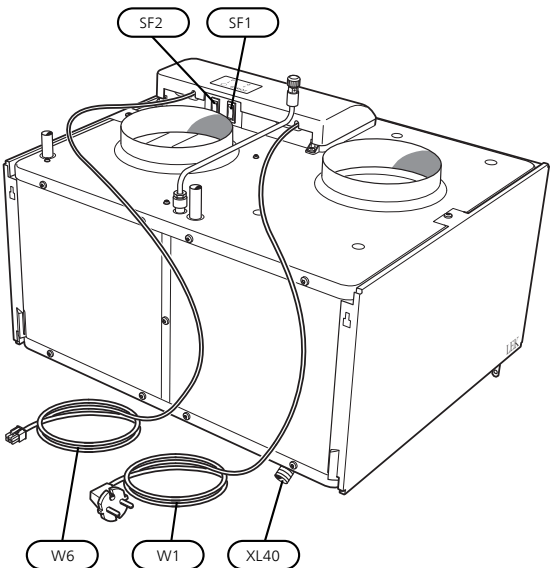
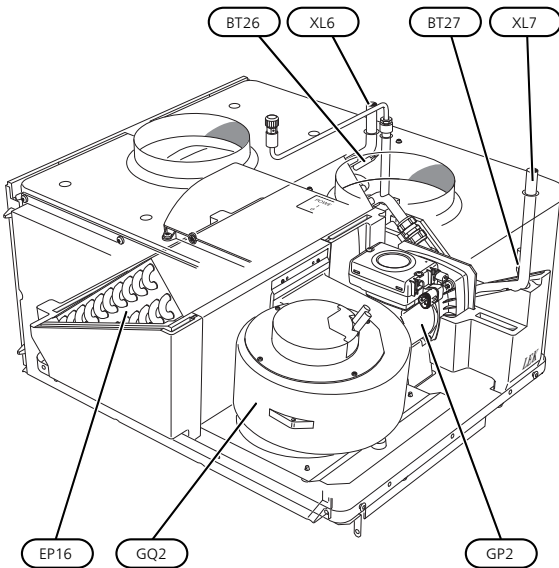
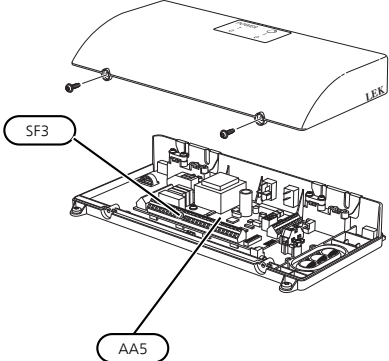
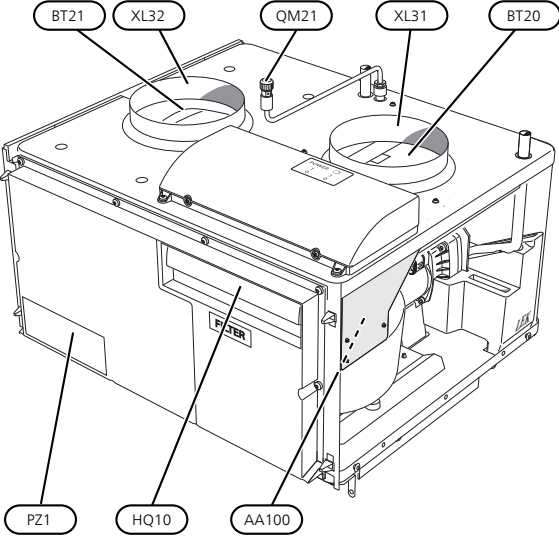

Pipe connections

| | |
|------|---|
| XL6 | Connection, brine in, compression ring Ø 15 mm |
| XL7 | Connection, brine out, compression ring Ø 15 mm |
| XL31 | Ventilation connection exhaust air, Ø 160 mm |
| XL32 | Ventilation connection extract air, Ø 160 mm |
| XL40 | Drip-pan drain |

HVAC components

| | |
|------|-------------------------|
| EP16 | Heat exchanger |
| GP2 | Circulation pump, brine |
| QM21 | Venting brine |

Sensors etc.

| | |
|------|-----------------------------------|
| BT20 | Temperature sensor, exhaust air |
| BT21 | Temperature sensor, extract air |
| BT26 | Temperature sensor, collector in |
| BT27 | Temperature sensor, collector out |

Electrical components

| | |
|-------|--|
| AA5 | Accessory card |
| AA100 | Joint card |
| SF1 | Switch, position 0 - 1, main switch |
| SF2 | Switch, position 0 - 1, circulation pump |
| SF3 | Potentiometer |
| W1 | Cord with connection plug |
| W6 | Communication cable |

Ventilation

| | |
|------|--------------------|
| GQ2 | Exhaust air fan |
| HQ10 | Exhaust air filter |

Miscellaneous

| | |
|-----|------------|
| PZ1 | Type plate |
|-----|------------|

Designations according to standard EN 81346-2.

4 Pipe and ventilation connections













General pipe connections

Pipe installation must be carried out in accordance with current norms and directives.

Lowest permitted temperature of incoming brine is -8°C.

Pipes and other cold surfaces must be insulated with diffusion-proof material to prevent condensation.

SYMBOL KEY

| Symbol | Meaning |
|---|------------------------------|
|  | Shut-off valve |
|  | Non-return valve |
|  | Circulation pump |
|  | Expansion vessel |
|  | Filterball |
|  | Fan |
|  | Pressure gauge |
|  | Safety valve |
|  | Trim valve |
|  | Manual reversing valve/shunt |
|  | Bore hole |
|  | Ground collector |
|  | Heat pump |

OUTLINE DIAGRAM

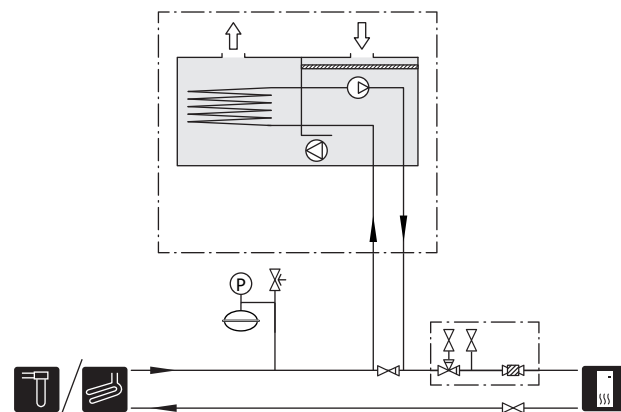

The brine system must be fitted with a pressure expansion vessel and a particle filter or filterball. In order to make any future servicing easier, one or more shut-off valves should be fitted.



NOTE

Venting may be necessary during installation and after a period of use. Venting takes place through vent valve (QM21). When venting, set the switch for the circulation pump (SF2) to position "0".

COMPATIBLE NIBE HEAT PUMPS

FLM S45 ventilates the building and preheats the brine, regardless of which ground source heat pump is installed, but when FLM S45 is installed together with a compatible ground source heat pump, it is possible to adjust settings and read off sensor values etc. in the heat pump's display.

Compatible products

- S1155
- S1255

Dimensions and pipe connections

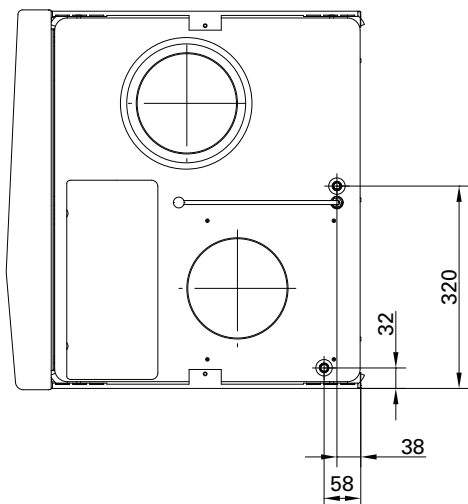
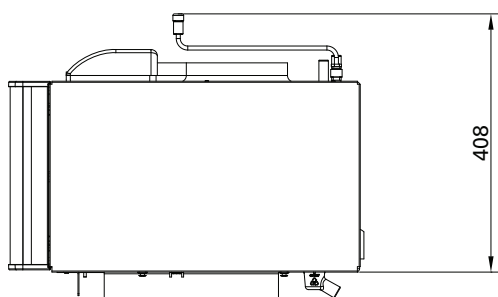
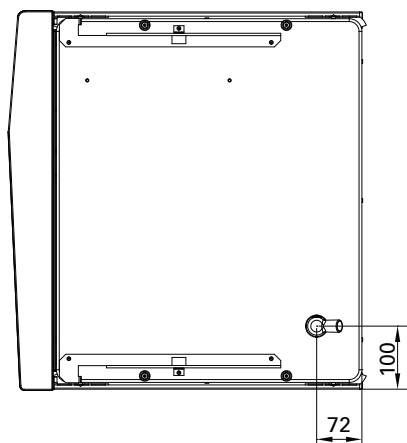

Mounting

CONNECTING TO COMPATIBLE PRODUCT

1. Remove the front cover from the heat pump.
2. Remove the top panel from the heat pump (installed with 6 screws).
3. Remove the cover in front of the circuit board.



Caution

A description of the removal of panels and covers can be found in the manual for the compatible product.

4. Remove the display.

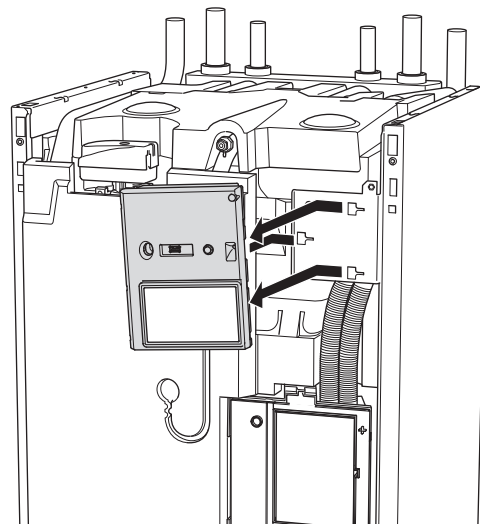

5. Install FLM S45 from the top and slide into position.

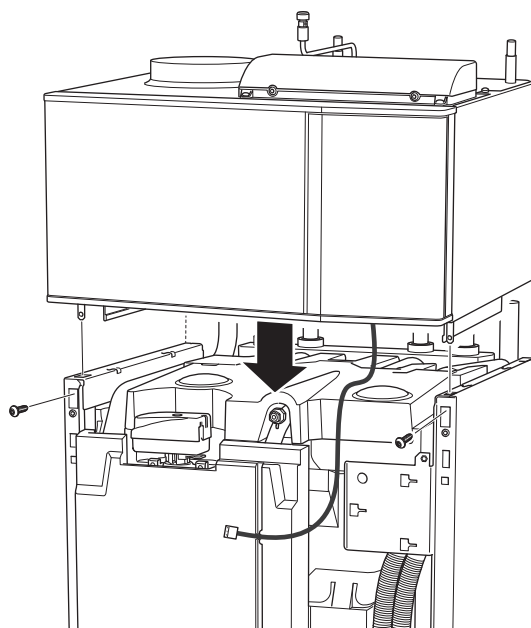

6. Secure FLM S45 with the 2 screws supplied.

- Route the communication cable from FLM S45 as illustrated.

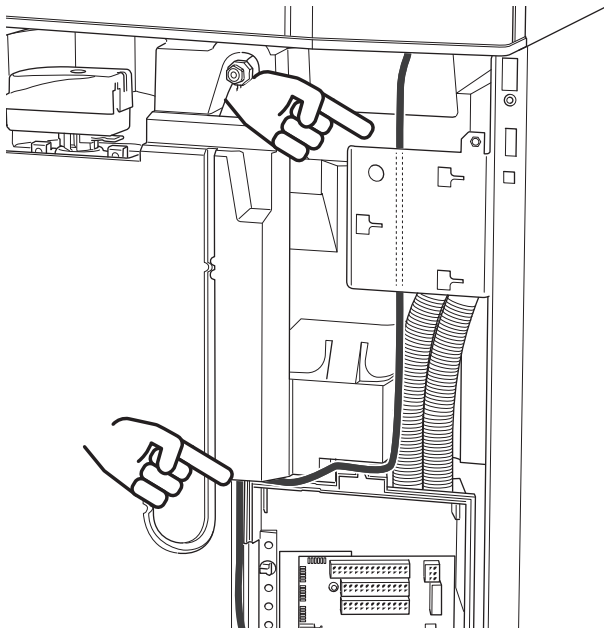

INSTALLING ON BRACKETS

FLM S45 can also be installed freestanding on the bracket BAU 40.

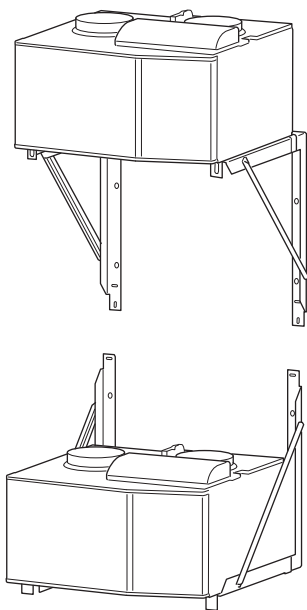

Brine side

OUTPUT TRANSFER TO BRINE

Output transfer to brine

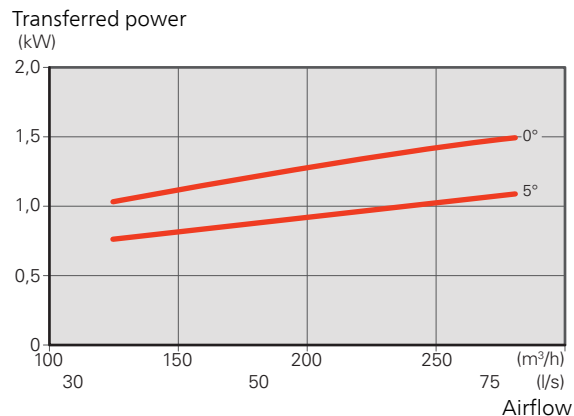

The diagram shows the power that is transferred from the ventilation air to the brine at 0°C and 5°C, and applies to an air temperature of +20°C and 50% relative air humidity.

EXPANSION VESSEL

The brine circuit must be provided with pressure expansion vessel (CM3). If there is a level vessel (CM2), this should be replaced. The brine side must be pressurised to at least 0.5 bar.

To prevent malfunctions, the pressure expansion vessel should be dimensioned as set out in the diagram. The pressure expansion vessel covers the temperature range from -10°C to +20 °C for the brine at a pre-pressure of 0.5 bar and with the safety valve's opening pressure set at 3 bar.

Expansion vessel

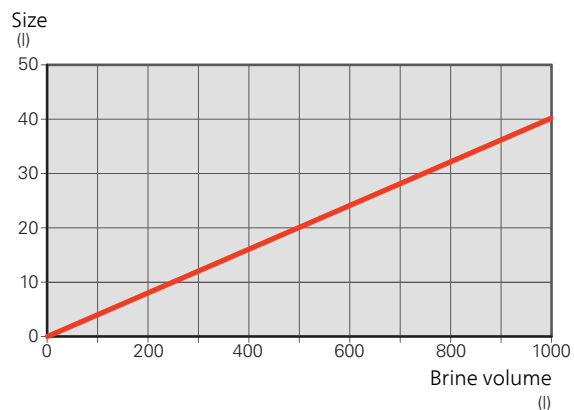

Condensation water hose

1. Connect the condensation water hose to the drip-pan drain (XL40).
2. Shape the hose into a water seal (see image). If FLM S45 is connected to S1255, there is space for the hose and the water seal in the heat pump's insulation.
3. Route the hose to a floor drain or similar.
4. Refill the water seal with water.

Ensure that the end of the hose runs out above the water level in the floor drain. The hose must be easily accessible for future cleaning.

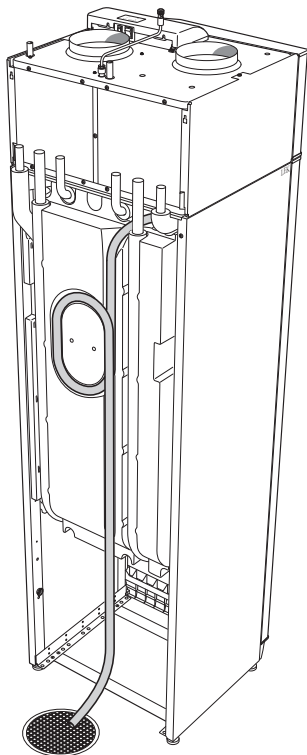

General ventilation connection

- Ventilation installation must be carried out in accordance with current norms and directives.
- Connections must be made via flexible hoses, which should be installed so that they are easy to replace.
- Provision must be made for inspection and cleaning of the duct.
- Make sure that there are no reductions of cross-sectional area in the form of creases, tight bends, etc., since this will reduce the ventilation capacity.
- The air duct system must be a minimum of air tightness class B.
- To prevent fan noise being transferred to the ventilation devices, silencers should be installed in the duct system. In the event of ventilation devices in noise-sensitive rooms, silencers must be installed.
- The extract air duct and ducts intended for supply air for FLM cooling have to be insulated with diffusion-proof material (at least PE30 or equivalent) along their entire length.
- Ensure that the condensation insulation is fully sealed at any joints and/or at lead-in nipples, silencers, roof cowls or similar.
- A duct in a masonry chimney stack must not be used for extract air.

EXHAUST AIR DUCT /KITCHEN FAN

Exhaust air duct (kitchen fan) must not be connected to FLM S45.

To prevent food vapour being transferred to FLM S45 the distance between the kitchen fan and the exhaust air device must be considered. The distance should not be less than 1.5 m, but this can vary between different installations.

Always use a kitchen fan when cooking.

Ventilation flow

Connect FLM S45 so that all the exhaust air, except kitchen duct air (kitchen fan), passes through the heat exchanger (EP16) in the product.

The ventilation flow must comply with the applicable national standards.

If the exhaust air module is connected to a compatible heat pump, set the ventilation capacity in the heat pump's menu system (menu 7.1.4.1). Otherwise, set the ventilation capacity via potentiometer (AA5-SF3).

Adjusting ventilation

To obtain the necessary air exchange in every room of the house, the exhaust air devices must be correctly positioned and adjusted and the fan in the exhaust air module adjusted.

Immediately after installation adjust the ventilation so that it is set according to the projected value of the house.

Incorrect adjustment of the ventilation may lead to reduced installation efficiency and thus poorer operating economy, and may cause moisture damage in the building

Dimension and ventilation connections

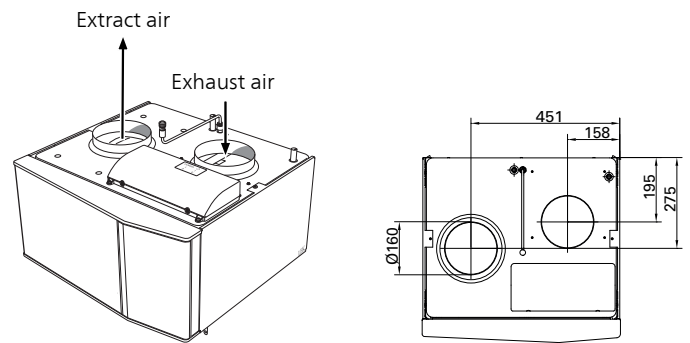

Installation alternative

ANOTHER HEAT PUMP

When FLM S45 is installed together with another heat pump, the brine circuit is supplied with a trim valve (RN1). This is necessary for adjusting the brine flow.

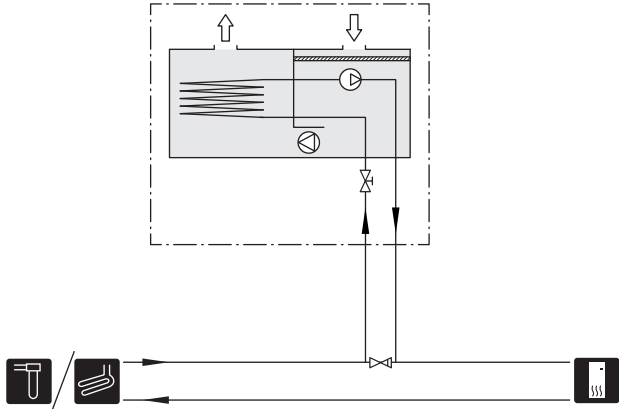

FLM COOLING

Where cooling is prioritised, FLM S45 can be installed in the brine circuit after the heat pump in the direction of flow.

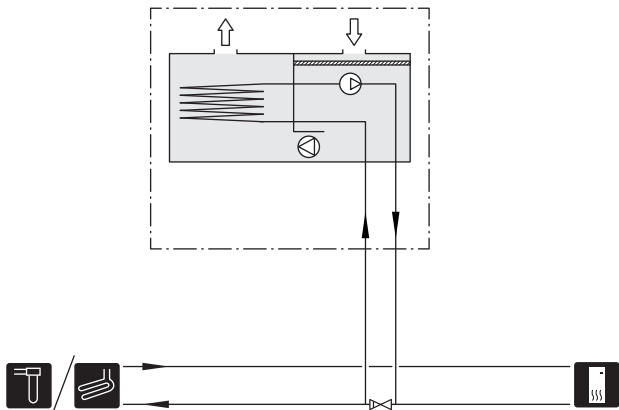

FLM cooling Requires an external fan (GQ4), four dampers that are controlled by two motors (QM40), (QM41) and a non-return damper (RM2). A room sensor (AZ10-BT50) is also required in one of the rooms where cooling is required. For electrical connection, see page 20.

The external fan (GQ4) takes over ventilation, which is led out of the house without recovery. At the same time, FLM S45 circulates air to and from other rooms where cooling is required, normally two to three bedrooms.

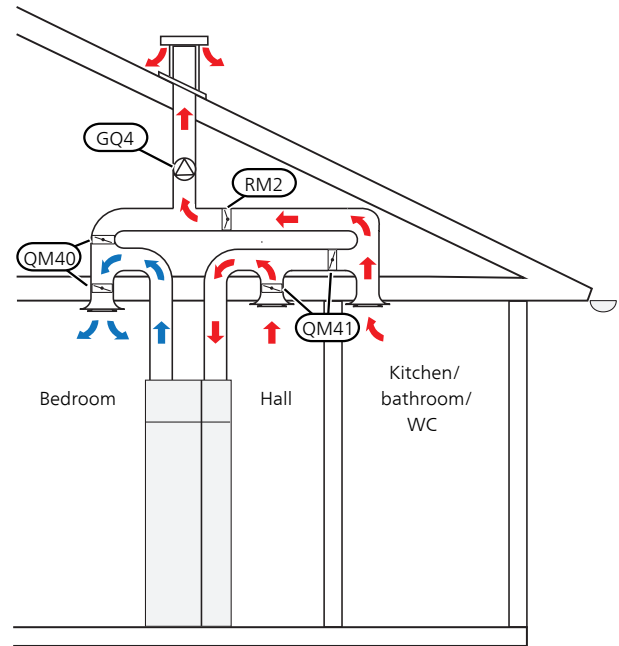

Normal operation.

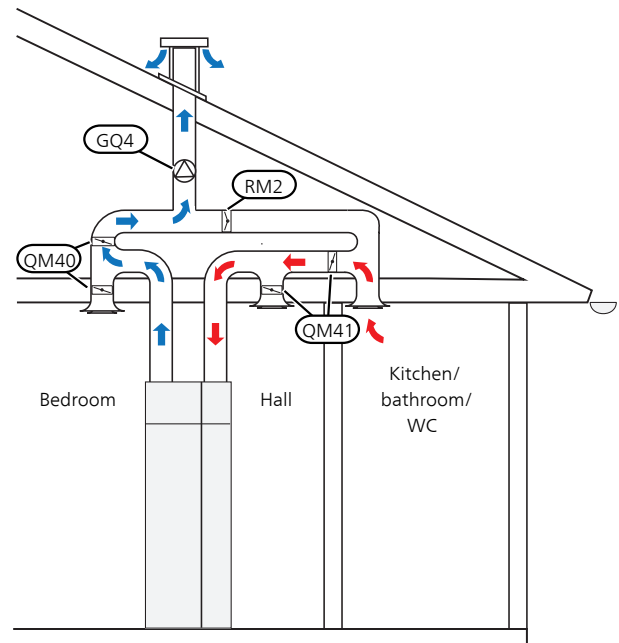



NOTE

When installing with cooling, the supply air ducts have to be insulated with diffusion-proof material (at least PE30 or equivalent) along their entire length.

5 Electrical connections

General

All electrical equipment is connected at the factory.

- Disconnect FLM S45 before insulation testing the house wiring.
- For the exhaust air module wiring diagram, see page 33.
- Signal cables to external connections must not be laid close to high current cables.
- If the supply cable is damaged, only NIBE, its service representative or similar authorised person may replace it to prevent any danger and damage.



NOTE

Electrical installation and service must be carried out under the supervision of a qualified electrician. Electrical installation and wiring must be carried out in accordance with the stipulations in force.

Connections

CONNECTING TO COMPATIBLE HEAT PUMP

Connection of supply to FLM S45

The exhaust air module is connected to an earthed single phase wall socket or a permanent installation. For permanent installations, FLM S45 must be preceded by a circuit breaker with at least a 3 mm breaking gap.

Connecting the communication to FLM S45 no. 1

S1155/S1255: The communication control cable (W6) with connector connects to contact X6 on the PCB (AA2) in the main product.

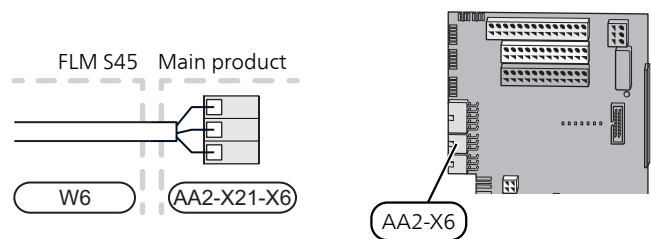

The DIP switch (AA5-S2) has to be set as follows.

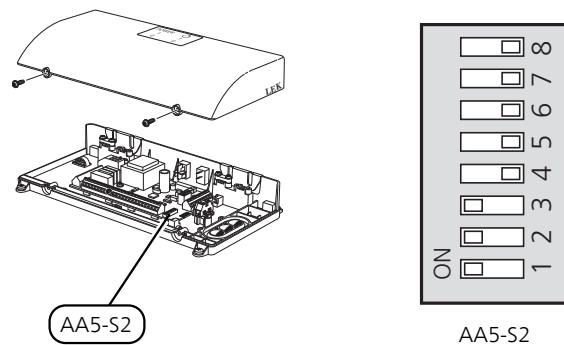

Connecting the communication to FLM S45 no. 2-4

FLM S45 no. 2 connects directly to the main product on the PCB (terminal block AA2-X30).

FLM S45 no. 3 connects to the accessory board's terminal block (AA5-X4) in FLM S45 no. 2.

FLM S45 no. 4 connects in a similar way in FLM S45 no. 3.

Use cable type LiYY, EKKX or similar.

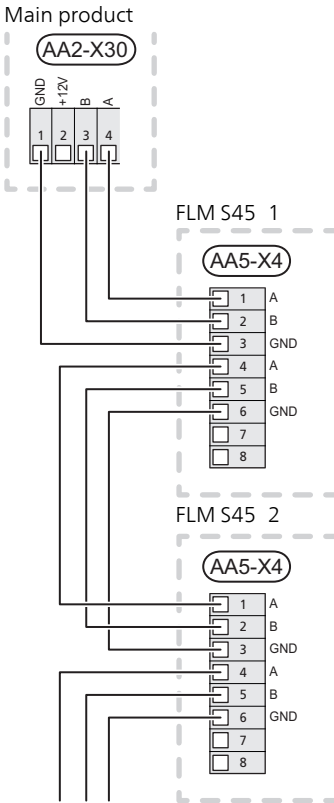

FLM S45 2-4 can be connected in a similar way to a previously installed accessory and its accessory board.

The DIP switch (AA5-S2) must be set as follows.

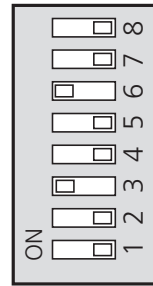
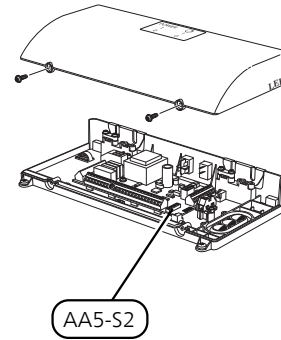

AA5-S2
FLM S45 no. 2

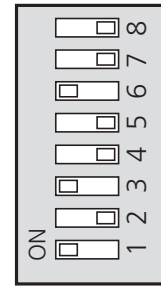

AA5-S2
FLM S45 no. 3

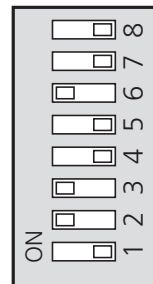

AA5-S2
FLM S45 no. 4

CONNECTING TO ANOTHER HEAT PUMP

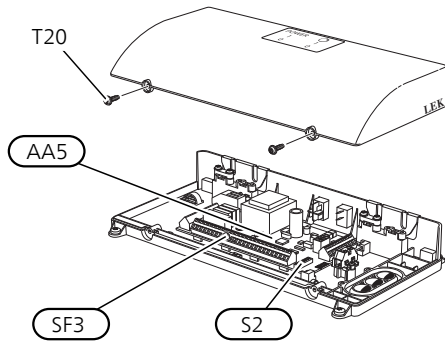

Connecting the supply

The exhaust air module is connected to an earthed single phase wall socket or a permanent installation. For permanent installations, FLM S45 must be preceded by a circuit breaker with at least a 3 mm breaking gap.

Circulation pump for brine (GP2)

Disconnect the PWM cable from terminal block AA5-X2:7-8. Insulate the wires properly.

Connecting communication

For installation with another heat pump, do not connect the communication cable (W6).

The DIP switch (AA5-S2) must be set as follows.

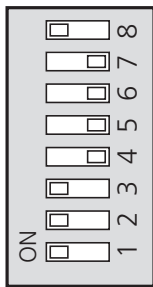

AA5-S2

OPTIONAL CONNECTIONS

Room sensor for FLM cooling

For optimum function, a separate room sensor (AZ10-BT50) should be connected when installing with cooling. This sensor is placed in the room that is to be kept coolest. The room sensor has up to three functions:

- Offers the opportunity to set a different target temperature in the room that is to be kept coolest.
- Show current room temperature in the display on the heat pump.
- Provides the opportunity to activate FLM cooling.

Install the sensor in a neutral position where the set temperature is required, 1.5 m above the floor. It is important that the sensor is not prevented from measuring the correct room temperature, for example by being located in a recess, between shelves, behind a curtain, above or close to a heat source, in a draught from an external door or in direct sunlight. Closed radiator thermostats can also cause problems.

Connection of room sensor for FLM cooling

Room sensor (AZ10-BT50) is connected to any AUX input (AA2-X28:3-11) and to GND (AA2-X29) in the compatible main product.

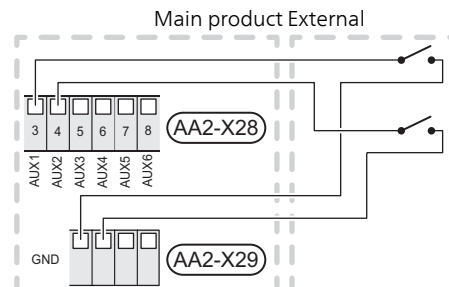

Connection of duct fan and damper for FLM cooling

Connect the fan (GQ4) and the damper (QM40) (QM41) for AA5-X9:4 (signal), AA5-X9:3 (N) and AA5-X10:2 (230V).

The connection on AA5-X10 and PE are occupied and these must be spliced with a clamp.

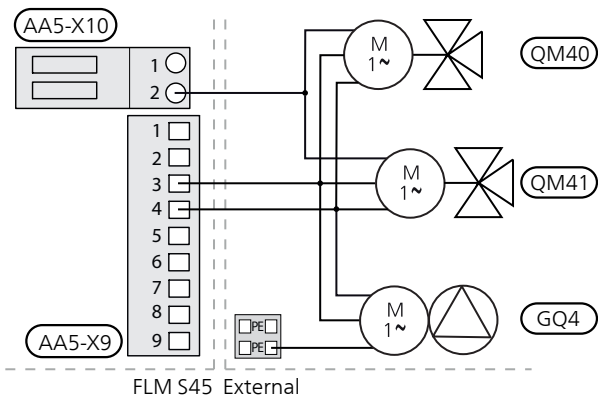
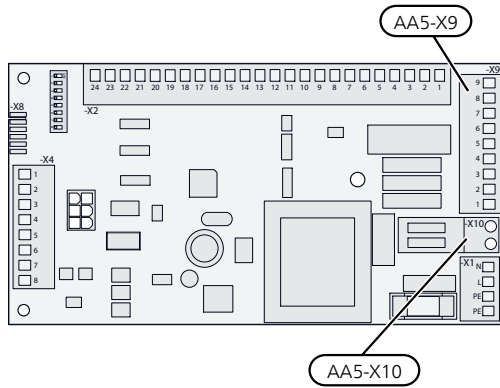

6 Commissioning and adjusting

Preparations

1. Make sure the heat pump is switched off.
2. Check that the filling valves are fully closed (see image).

Filling and venting



Caution

Insufficient venting can damage internal components in FLM S45.

FILLING AND VENTING THE BRINE SYSTEM

When filling the brine system, mix the water with anti-freeze in an open container. The mixture should be protected against freezing down to about -15°C . The brine is topped up by connecting a filling pump.

1. Check that the level vessel is replaced with an expansion vessel.
2. Check the brine system for leakage.
3. Connect the filling pump and return line on the brine system's filling connection (accessory).
4. Close the reversing valve in the filling connection.
5. Open the valves on the filler connector.
6. Start the filling pump.
7. Fill until liquid enters the return pipe.
8. Vent the brine system with vent valve (QM21) on FLM S45.
9. Close the valves on the filler connector.
10. Open the reversing valve in the filling connection.

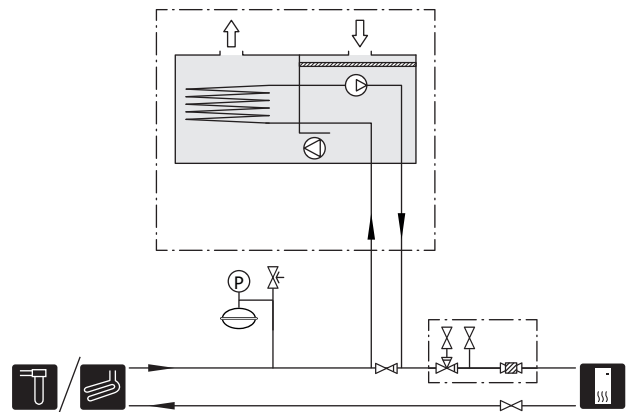

NOTE

Venting may be necessary during installation and after a period of use. Venting takes place through vent valve (QM21). When venting, set the switch for the circulation pump (SF2) to position "0".

Start-up and inspection



NOTE

There must be water in the climate system before FLM S45 is started.

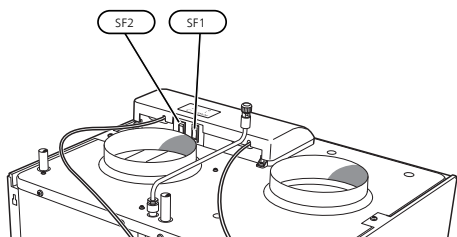

STARTING-UP WITH ANOTHER HEAT PUMP

1. Set the main switch (SF1) and the switch for the circulation pump (SF2) on FLM S45 to position "1".
2. Check that the fan (GQ2) and the circulation pump (GP2) are in operation.
3. Set the speed of the fan using the potentiometer (SF3).
4. Start the heat pump.

START-UP WITH COMPATIBLE HEAT PUMP

1. Set the main switch (SF1) and the switch for the circulation pump (SF2) on FLM S45 to position "1".
2. Start the heat pump.
3. Follow the instructions in the display's start guide. If the start guide does not start when you start the heat pump, you can start it manually in menu 7.7.
4. Check that the fan (GQ2) and circulation pump (GP2) are running.

STARTING-UP WITH VENTILATION ONLY

It is possible to run FLM S45 with only ventilation, e.g. before the brine side is ready for connection. In this mode, the circulation pump must be switched off.

1. Follow the instructions on page 23, but leave the switch for circulation pump (SF2) in "0" mode.
2. When the brine side is connected, the switch for circulation pump (SF2) is set to "1" mode.

SETTING THE VENTILATION

7.1.4.1.

The ventilation must be set according to applicable standards. If FLM S45 is connected to a compatible heat pump, the setting is adjusted in menu 7.1.4.1. Otherwise the ventilation is set via potentiometer (AA5-SF3).

Even if ventilation is roughly set at installation it is important that a ventilation adjustment is ordered and permitted.



NOTE

Order a ventilation adjustment to complete the setting.

Ventilation capacity

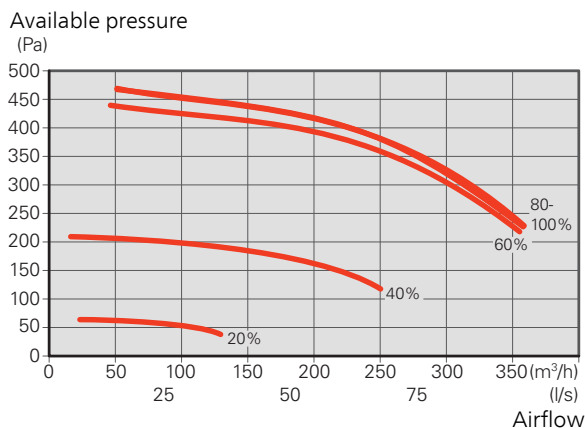

Power direct current fan

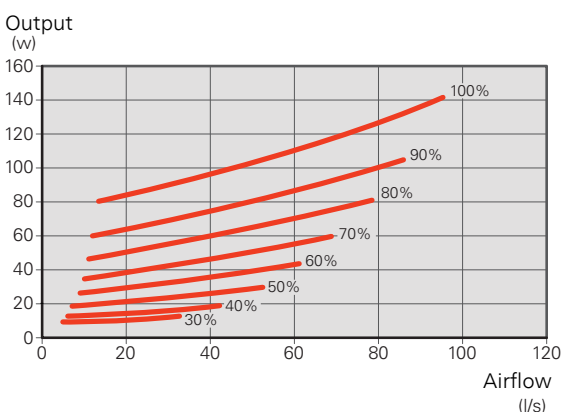

SETTING THE BRINE FLOW

Set the brine flow so that the temperature difference between the brine entering and leaving FLM S45 is 2–4°C. The temperature is measured using external measuring equipment.

Compatible heat pump: The brine flow over FLM S45 is regulated by the trim valve (RN1) and the circulation pump (GP2).

Other heat pumps: The brine flow over FLM S45 is regulated by the trim valve (RN1) and the brine pump in the heat pump.

Adjustments are made when the heat pump is in operation. Temperature difference applies at 20 °C room temperature and 0 °C in the brine.

The brine flow through FLM S45 will be from 0.1 l/s (360 l/h) to 0.15 l/s (540 l/h) at the above temperature difference, depending on the ventilation flow.

When the heat pump is at a standstill, the internal circulation pump in FLM S45 gives from 0.085 l/s (306 l/h) to 0.125 l/s (450 l/h) in the return charging flow to the collector.

This applies to a heat pump with approximately 4 kW rated output.

For a 15 kW heat pump, the corresponding flow is from 0.09 l/s (324 l/h) to 0.14 l/s (504 l/h).

SETTING PUMP SPEED

Set the speed of the circulation pump (GP2) in menu 7.2.2. For other heat pumps, the trim valve (RN1) is used to set the flow.

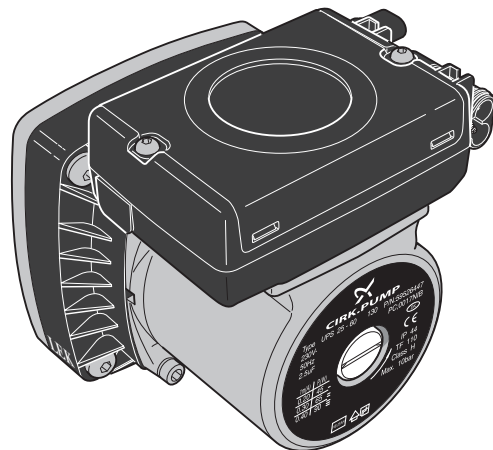

Capacity circulation pump

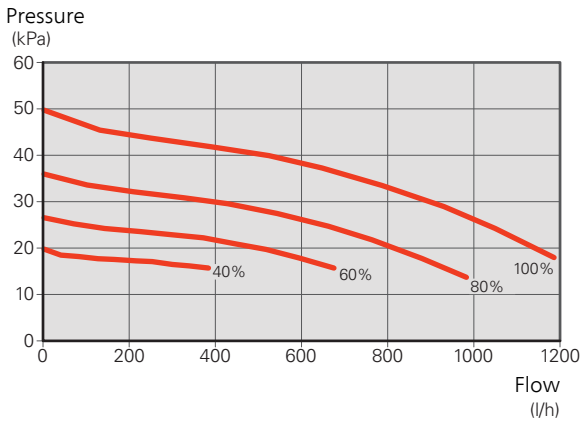

Output circulation pump

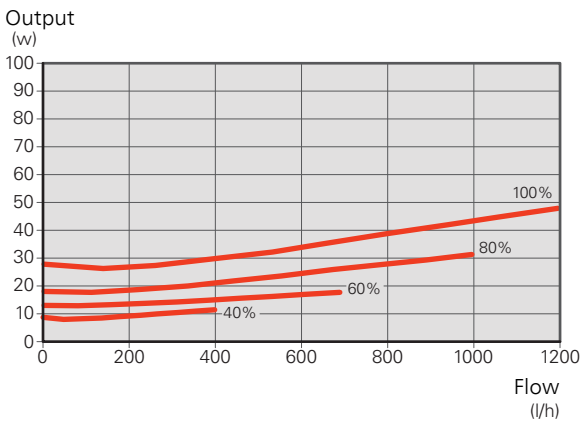

7 Program settings

Program setting of FLM S45 can be performed via the start guide or directly in the menu system in the compatible heat pump.



Caution

Also see the Installer manual for the heat pump.

Menu system

If you do not make all settings via the start guide or need to change any of the settings, this can be done in the menu system.

MENU 7.2.1. - ADD/REMOVE ACCESSORIES

Activating/deactivating of accessories.

Select "exhaust air module 1-4".

MENU 7.2.2 - EXHAUST AIR MODULE (NIBE FLM/FLM S45)

continuous pump op.

Setting range: on/off

Pump speed

Setting range: 1-100%

time between defrosts

Setting range: 1 – 30 h

activate cooling

Setting range: on/off

continuous pump op.: Select for continuous operation of the circulation pump in the exhaust air module.

pump speed: You can set the speed of the exhaust air module's circulation pump here.

time between defrosts: Set the minimum time that must pass between defrostings of the heat exchanger in the exhaust air module.

When the exhaust air module is in operation the heat exchanger is cooled so that ice builds up on it. When too much ice builds up the heat transfer capacity of the heat exchanger is reduced and defrosting is required. Defrosting warms up the heat exchanger so that the ice melts and runs off via the condensation hose.

Clean the exhaust air module's air filter regularly, how often depends on the amount of dust in the ventilation air.

activate cooling: Activate cooling via the exhaust air module here. When the function has been activated, the cooling settings are displayed in the menu system.

MENU 7.1.4.1 - FAN SPEED EXHAUST AIR

Normal and Speed 1-4

Setting range: 0 – 100 %

Set the speed for the five different selectable speeds for the fan here.

MENU 1.2.1 - FAN SPEED

Alternatives: Normal and speed 1-4

The ventilation in the accommodation can be temporarily increased or reduced here.

When you have selected a new speed a clock starts a count down. When the time has counted down the ventilation speed returns to the normal setting.

If necessary, the different return times can be changed in menu 1.2.5.

The fan speed is shown in brackets (in percent) after each speed alternative.

MENU 1.2.5 - FAN RETURN TIME

Select the return time here for the temporary speed change (speed 1-4) of the ventilation in menu 1.2.1.

Return time is the time taken before the ventilation speed returns to normal speed.

MENU 1.2.6 - FILTER CLEANING INTERVAL

Cleaning interval

Setting range: 1 – 24 months

Clean the filter in FLM S45 regularly; how often depends on the amount of dust in the ventilation air.

Set the interval for the reminder to clean the filter in this menu.

The menu shows the time remaining until the next reminder, and you can also reset active reminders.

MENU 1.2.2 - NIGHT COOLING

Start temperature, exhaust air

Setting range: 20 – 30 °C

Lowest diff., outdoor/exhaust air

Setting range: 3 – 10 °C

Activate night cooling here.

When the temperature in the house is high and the outdoor temperature is lower, a cooling effect can be obtained by forcing the ventilation.

If the temperature difference is greater than the set value for "Min diff outdoor and exhaust air", and the exhaust air temperature is higher than the set value for "Start temperature exhaust air", the ventilation operates at speed 4 until one of these conditions is no longer valid.



Caution

Night cooling is only activated when heating is not permitted.

MENU 7.4 - SELECTABLE IN/OUTPUTS

Here you select the room sensor for FLM cooling (AZ10-BT50) on the relevant AUX input.

MENU 1.2.3 - FLM COOLING

Room set point value

Setting range: 5 – 40 °C

Cooling at room over temp

Setting range: 1 – 10 °C

When you have activated FLM cooling in menu 7.2.2, set the desired room temperature in this menu. You also select the temperature at which cooling will start.

FLM cooling starts when the room temperature exceeds the set *Room set point value* + *Cooling at room over temp*.

FLM cooling stops when the room temperature falls below *Room set point value*.

In systems with several FLM, settings can be made for each FLM unit.

8 Service

Service actions

HELPING THE CIRCULATION PUMP TO START

1. Shut off FLM S45.
2. Remove the front cover
3. Remove the fan.
4. Loosen the venting screw (QM5) with a screwdriver. Hold a cloth around the screwdriver blade as a small amount of water may run out.
5. Insert a screwdriver and turn the pump motor around.
6. Screw in the venting screw (QM5).
7. Start FLM S45 and check that the circulation pump is working.

It is often easier to start the circulation pump with FLM S45 running. If the circulation pump is helped to start with FLM S45 running, be prepared for the screwdriver to jerk when the pump starts.

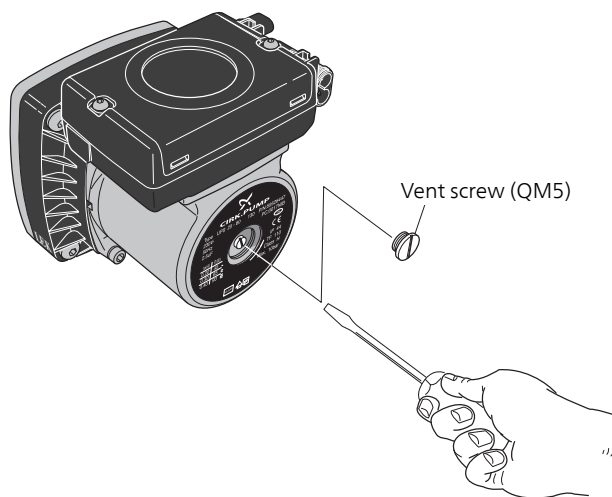

9 Disturbances in comfort

In most cases, the compatible heat pump notes a malfunction (a malfunction can lead to disturbance in comfort) and indicates this with alarms and action instructions in the display.

Troubleshooting

If the malfunction does not appear in the display or FLM S45 is not connected to a compatible heat pump, the following tips can be used:

BASIC ACTIONS

Start by checking the following items:

- That the heat pump is running or that the supply cable to FLM S45 is connected.
- Group and main fuses of the accommodation.
- The property's earth circuit breaker.

LOW OR A LACK OF VENTILATION

- Filter (HQ10) blocked.
 - Clean or replace the filter.
- The ventilation is not adjusted.
 - Order/implement ventilation adjustment.
- Exhaust air device blocked or throttled down too much.
 - Check and clean the exhaust air devices.
- Fan speed in reduced mode.
 - 1.2.1 and select "normal".
If FLM S45 is connected to a compatible heat pump:
Enter menu 1.2.1 and select "normal".
If FLM S45 is connected to another heat pump:
Check the potentiometer (SF3).
- External switch for changing the fan speed activated.
 - Check any external switches.

HIGH OR DISTRACTING VENTILATION

- Filter (HQ10) blocked.
 - Clean or replace the filter.
- The ventilation is not adjusted.

- Order/implement ventilation adjustment.
- Fan speed in forced mode.
 - If FLM S45 is connected to a compatible heat pump:
Enter menu 1.2.1 and select "normal".
If FLM S45 is connected to another heat pump:
Check the potentiometer (SF3).
- External switch for changing the fan speed activated.
 - Check any external switches.

GURGLING SOUND

- Not enough water in the water seal.
 - Refill the water seal with water.
- Choked water seal.
 - Check and adjust the condensation water hose.

10 Accessories

Some accessories manufactured before 2019 may need to have their circuit board updated in order to be compatible with FLM S45. For more information, see the Installer Manual for the relevant accessory.

BRACKET BAU 40

Wall mounting of FLM S45.

Part no. 067 666

TOP CABINET TOC 30

Top cabinet, which conceals any pipes/ventilation ducts.

Height 245 mm

Height 345 mm

Part no. 067 517

Part no. 067 518

Height 385-635 mm

Part no. 067 519

11 Technical data

Dimensions and setting-out coordinates

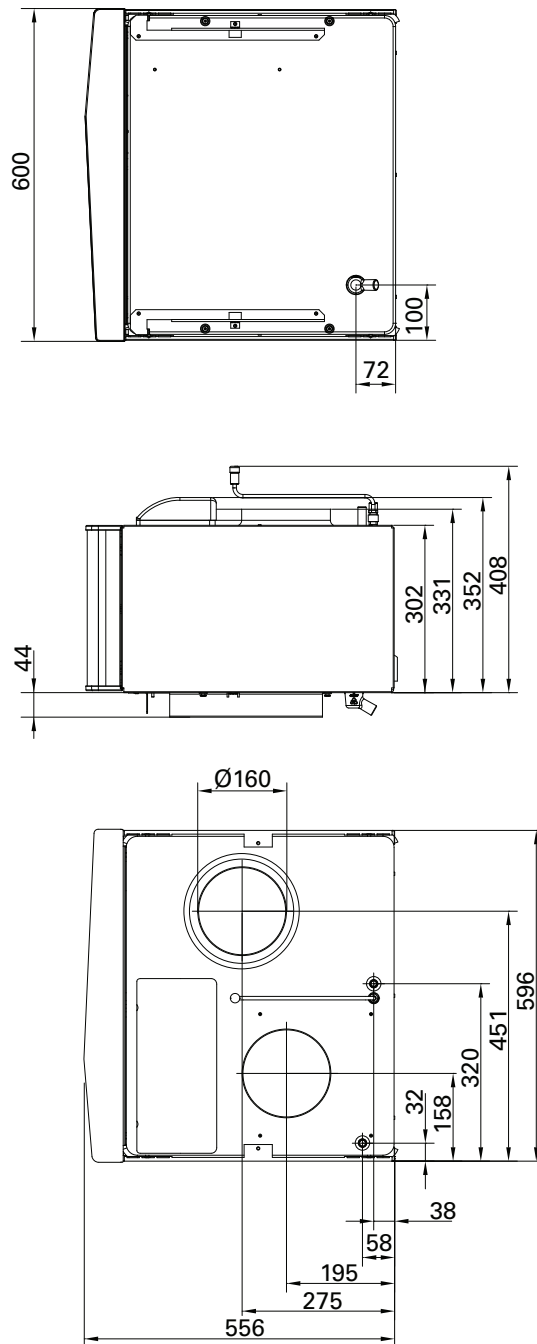

Technical specifications

| <i>FLM S45</i> | | |
|---|-------------------|-----------------|
| <i>Electrical data</i> | | |
| Supply voltage | V | 230 V NAC 50 Hz |
| Max driving power circulation pump | W | 70 |
| Driving power fan | W | 175 |
| Enclosure class | | IP21 |
| <i>Ventilation</i> | | |
| Max airflow | m ³ /h | 350 |
| <i>Brine circuit</i> | | |
| Minimum incoming brine temperature | °C | -8 |
| Maximum recommended incoming brine temperature | °C | 15 |
| Maximum outgoing brine temperature | °C | 30 |
| Min pressure brine | MPa/bar | 0.02/0.2 |
| Maximum pressure brine | MPa/bar | 0.3/3 |
| <i>Sound effect level according to EN 12 102</i> | | |
| Sound power level (L _{W(A)}) ¹ | dB(A) | 36-46 |
| <i>Miscellaneous</i> | | |
| Width | mm | 600 |
| Depth | mm | 556 |
| Height | mm | 396 |
| Weight | kg | 35 |
| Part No. | | 067 627 |

¹ The value varies with the selected fan curve.

Electrical circuit diagram

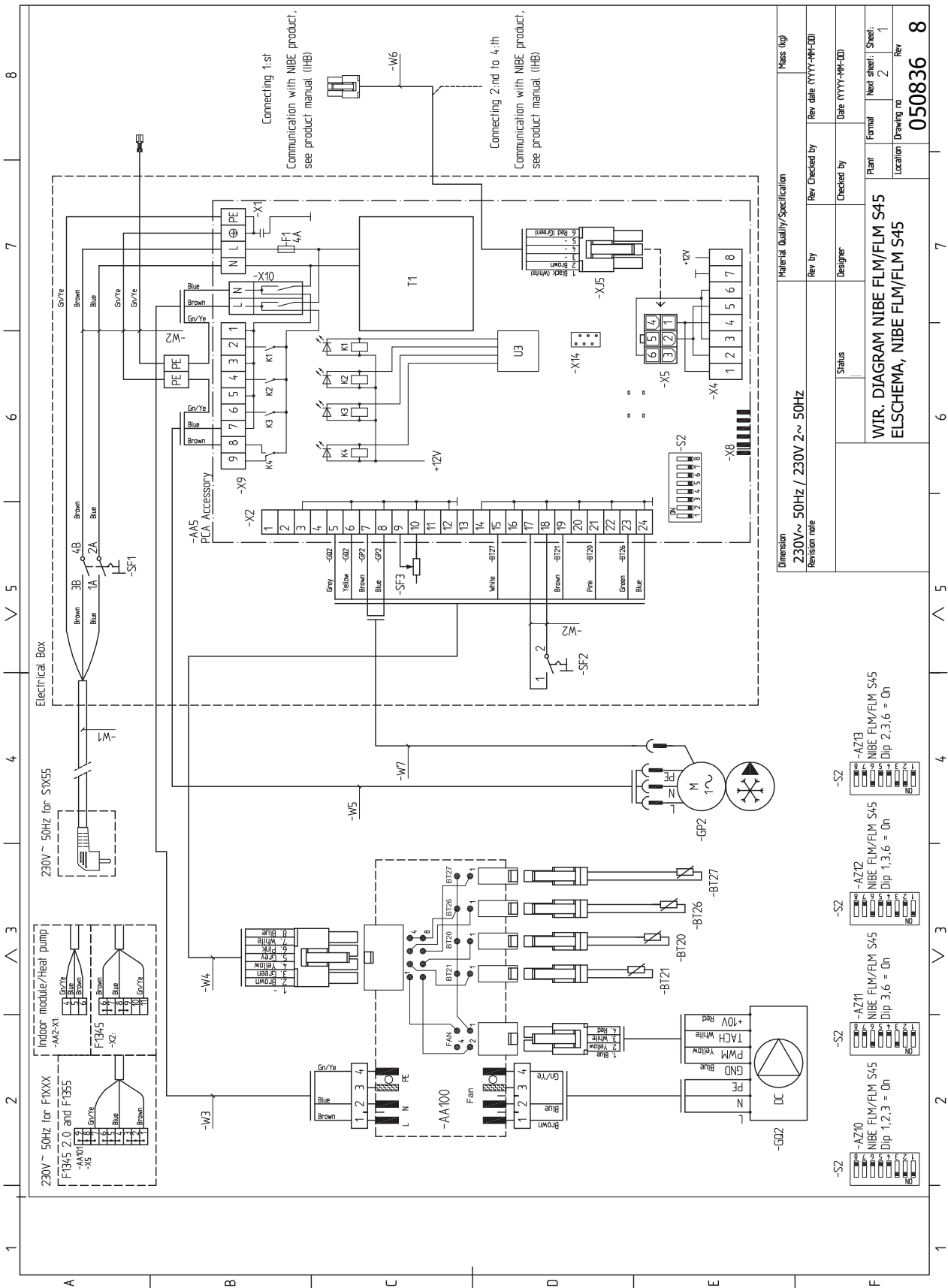

1 2 3 4 5 6 7 8

OPTIONAL CONNECTIONS:

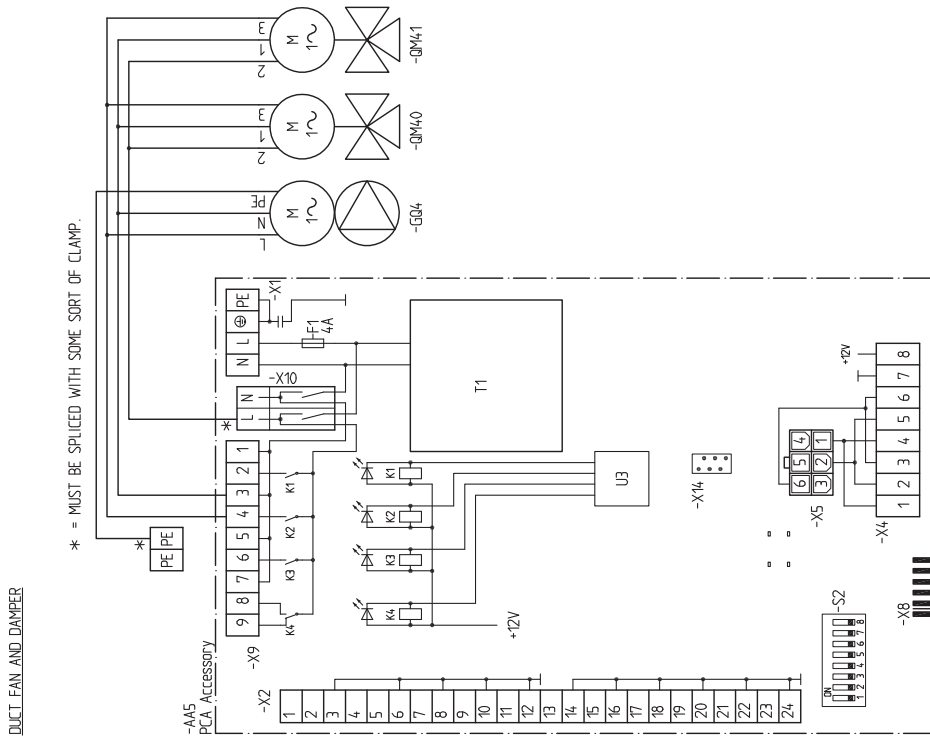

| | | | |
|---------------------------|--------------------------------|----------------|-----------------------|
| Dimension | Material Quality/Specification | | Mass (kg) |
| 230V~ 50Hz / 230V 2~ 50Hz | Rev by | Rev Checked by | Rev date (YYYY-MM-DD) |
| Revision note | Status | Designer | Date (YYYY-MM-DD) |
| | | Plant | Formal |
| | | Location | Drawing no |
| | | | Rev |
| | | | 050836 |
| | | | 8 |

Item register

A

- Accessories, 30
- Another heat pump, 16
- Assembly, 7

B

- Brine side, 13
 - Output transfer to brine, 13
 - Pressure expansion vessel, 13

C

- Commissioning and adjusting, 22
 - Filling and venting, 22
 - Preparations, 22
 - Start-up and inspection, 23
- Compatible NIBE heat pumps, 11
- Condensation water hose, 14
- Connecting to another heat pump, 20
- Connecting to compatible heat pump, 18

D

- Delivery and handling, 7
 - Installation area, 7
 - Removing the covers, 8
 - Supplied components, 8
- Dimensions and pipe connections, 12
- Dimensions and setting-out coordinates, 31
- Disturbances in comfort, 29
 - Troubleshooting, 29

E

- Electrical connections, 18
 - Connecting to another heat pump, 20
 - Connecting to compatible heat pump, 18
 - Connections, 18
 - General, 18
- Exhaust air duct, 15

F

- Filling and venting, 22
 - Filling and venting the brine system, 22
- Filling and venting the brine system, 22
- FLM cooling, 16

G

- General pipe connections
 - Compatible NIBE heat pumps, 11
 - Installation alternative
 - FLM cooling, 16

H

- Helping the circulation pump to start, 28

I

- Important information, 4
 - Recovery, 5
 - Safety information, 4
- Installation alternative
 - Another heat pump, 16
- Installation area, 7

M

- Marking, 4
- Mounting, 12–13
 - Connecting to another heat pump, 13
 - Connecting to F1145/F1155/F1245/F1255, 12

O

- Outline diagram, 11
 - General pipe connections, 11
- Output transfer to brine, 13

P

- Pipe and ventilation connections, 11
 - Brine side, 13
 - Condensation water hose, 14
 - Dimensions and pipe connections, 12
 - Exhaust air duct, 15
 - General pipe connections, 11
 - Mounting, 12
- Pipe connections
 - Symbol key, 11
- Preparations, 22
- Pressure expansion vessel, 13

R

- Removing the covers, 8

S

- Safety information, 4
 - Marking, 4
 - Serial number, 5
 - Symbols on FLM S45, 4
- Serial number, 5
- Service, 28
 - Service actions, 28
- Service actions, 28
 - Helping the circulation pump to start, 28
- Start-up and inspection, 23
 - Setting the pump speed, 24
 - Setting the ventilation, 24

- Starting-up with another heat pump, 23
- Start-up with compatible heat pump, 23
- Supplied components, 8
- Symbol key, 11
- Symbols on FLM S45, 4

T

- Technical data, 31
 - Dimensions and setting-out coordinates, 31
 - Technical Data, 32
- Technical Data, 32
- The design of the exhaust air module, 9
 - List of components, 10
- Transport
 - Assembly, 7
- Troubleshooting, 29

Contact information

AUSTRIA

KNV Energietechnik GmbH
Gahberggasse 11, 4861 Schörfling
Tel: +43 (0)7662 8963-0
mail@knv.at
knv.at

CZECH REPUBLIC

Družstevní závody Dražice - strojírna
s.r.o.
Dražice 69, 29471 Benátky n. Jiz.
Tel: +420 326 373 801
nibe@nibe.cz
nibe.cz

DENMARK

Vølund Varmeteknik A/S
Industrivej Nord 7B, 7400 Herning
Tel: +45 97 17 20 33
info@volundvt.dk
volundvt.dk

FINLAND

NIBE Energy Systems Oy
Juurakkotie 3, 01510 Vantaa
Tel: +358 (0)9 274 6970
info@nibe.fi
nibe.fi

FRANCE

NIBE Energy Systems France SAS
Zone industrielle RD 28
Rue du Pou du Ciel, 01600 Reyrieux
Tél: 04 74 00 92 92
info@nibe.fr
nibe.fr

GERMANY

NIBE Systemtechnik GmbH
Am Reiherpfahl 3, 29223 Celle
Tel: +49 (0)5141 75 46 -0
info@nibe.de
nibe.de

GREAT BRITAIN

NIBE Energy Systems Ltd
3C Broom Business Park,
Bridge Way, S41 9QG Chesterfield
Tel: +44 (0)845 095 1200
info@nibe.co.uk
nibe.co.uk

NETHERLANDS

NIBE Energietechnik B.V.
Energieweg 31, 4906 CG Oosterhout
Tel: +31 (0)168 47 77 22
info@nibenl.nl
nibenl.nl

NORWAY

ABK AS
Brobekkveien 80, 0582 Oslo
Tel: (+47) 23 17 05 20
post@abkklima.no
nibe.no

POLAND

NIBE-BIAWAR Sp. z o.o.
Al. Jana Pawla II 57, 15-703 Bialystok
Tel: +48 (0)85 66 28 490
biawar.com.pl

RUSSIA

EVAN
bld. 8, Yuliusa Fuchika str.
603024 Nizhny Novgorod
Tel: +7 831 419 57 06
kuzmin@evan.ru
nibe-evan.ru

SWEDEN

NIBE Energy Systems
Box 14
Hannabadsvägen 5, 285 21 Markaryd
Tel: +46 (0)433-27 3000
info@nibe.se
nibe.se

SWITZERLAND

NIBE Wärmetechnik c/o ait Schweiz
AG
Industriepark, CH-6246 Altishofen
Tel. +41 (0)58 252 21 00
info@nibe.ch
nibe.ch

For countries not mentioned in this list, contact NIBE Sweden or check nibe.eu for more information.

NIBE Energy Systems
Hannabadsvägen 5
Box 14
SE-285 21 Markaryd
info@nibe.se
nibe.eu

IHB EN 1926-1 531269

This manual is a publication from NIBE Energy Systems. All product illustrations, facts and data are based on the available information at the time of the publication's approval. NIBE Energy Systems makes reservations for any factual or printing errors in this manual.

©2019 NIBE ENERGY SYSTEMS

