

# Condensation water pipe KVR 10

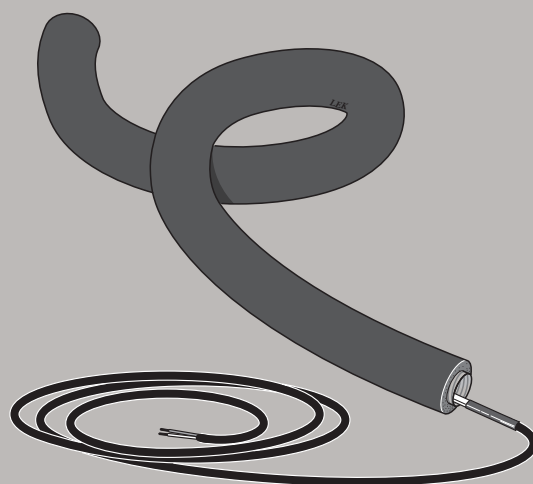



# Table of Contents

1	<i>General</i> _____	4
	Different versions of KVR 10 _____	4
2	<i>Pipe connections</i> _____	6
	General _____	6
	Drain indoors _____	6
	Stone caisson _____	7
	Gutter drainage _____	7
3	<i>Electrical connection</i> _____	8
	F2016 / F2026 _____	8
	F2030 / F2300 _____	10
	F2040 _____	12
	F2120 _____	20
	NIBE SPLIT HBS 05 / HBS 20 _____	23
	<i>Contact information</i> _____	31

# 1 General

The accessory KVR 10 is used to safely divert most of the condensation from the air/water heat pump to a frost-free collection point.

The accessory is suitable to following products from NIBE:

- F2016
- F2026
- F2030
- F2040
- F2120
- F2300
- NIBE SPLIT HBS 05
- NIBE SPLIT HBS 20



## NOTE

It is important to the heat pump function that condensation water is led away and that the drain for the condensation water run off is not positioned so that it can cause damage to the house.

The heating cable starts automatically at an outdoor temperature of 1.5 °C. When the temperature exceeds 2 °C the heating cable switches off again.



## NOTE

The installation of KVR 10 can affect the machine's function. Read the entire manual!

## Different versions of KVR 10

KVR 10 is available in three lengths. Here you can see an example of the installation length.

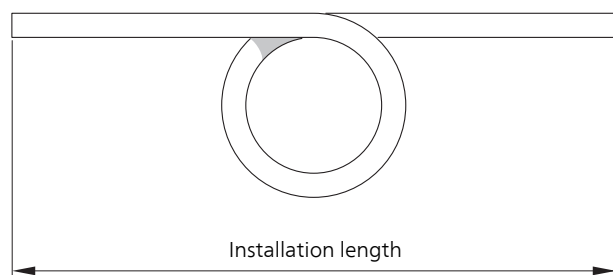

## F2120

	<i>KVR 10</i>	<i>KVR 10 2x230V</i>
	<i>Part No.</i>	<i>Part No.</i>
Hose length 1 metre (installation length 1 m without water seal)	067 549	067 553
Hose length 3 metres (installation length 1-2.2 m with water seal)	067 550	067 554
Hose length 6 metres (installation length 2.2-5.2 m with water seal)	067 551	067 555

## CONTENTS

- 1 x Insulated hose (inner diameter 40 mm)
- 1 x Heating cable
- 1 x Hose clamp
- 1 x Fuse
- 6 x Cable ties
- 1 x Automatic protection

## F2016, F2026, F2030, F2300, F2040, NIBE SPLIT HBS 05 / HBS 20

	<i>KVR 10</i>	<i>KVR 10 2x230V</i>
	<i>Part No.</i>	<i>Part No.</i>
Hose length 1 metre (installation length 1 m without water seal)	067 614	067 615
Hose length 3 metres (installation length 1-2.2 m with water seal)	067 616	067 617
Hose length 6 metres (installation length 2.2-5.2 m with water seal)	067 618	067 619

## CONTENTS

- 1 x Insulated hose (inner diameter 40 mm)
- 1 x Heating cable
- 1 x Hose clamp
- 1 x Fuse
- 1 x Gasket
- 6 x Cable ties
- 1 x Screw
- 1 x Nuts
- 2 x Washers
- 1 x Connection piece
- 1 x Residual current device RCD (only applies to F2040 and AMS 10 / AMS 20)
- 14 x Plug (only applies to F2040 and AMS 10 / AMS 20)
- 1 x Connection plate (only applies to AMS 10-6 / AMS 20-6)

# 2 Pipe connections

## General

Connect KVR 10 to the heat pump's condensation water trough using the supplied hose clamp.

- Pipe installation must be carried out in accordance with current norms and directives.
- We recommend three ways of leading off condensation water; to an indoor drain (subject to local rules and regulations), stone caisson, gutter drainage or other frost free collection point.
- When casting the base, the holes for KVR 10 must have an internal diameter of 110 mm.
- Route the pipe downward from the air/water heat pump.
- The insulation of KVR 10 must seal against the bottom of the product's condensation water trough.
- The drain from KVR 10 must be positioned at frost free depth or indoors (subject to local rules and regulations).
- The drain from KVR 10 must be able to receive up to 100 litres of condensation water per day.
- The installation must be equipped with a water seal where air circulation can occur in the condensation water pipe.

## Drain indoors

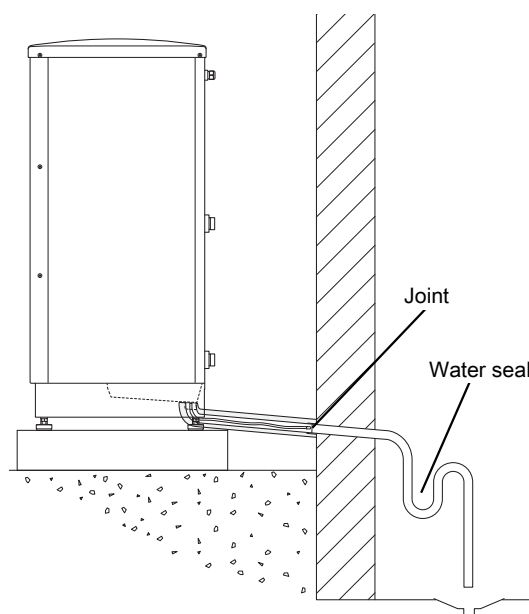

The condensation water is lead to an indoor drain (subject to local rules and regulations).

Route the pipe downward from the air/water heat pump.

The condensation water pipe must have a water seal to prevent air circulation in the pipe.

KVR 10 spliced as illustrated. Pipe routing inside house not included.

# Stone caisson

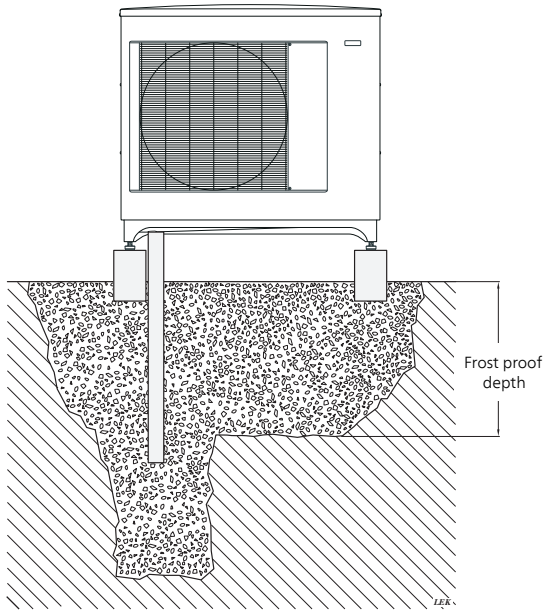

If the house has a cellar the stone caisson must be positioned so that condensation water does not affect the house. Otherwise the stone caisson can be positioned directly under the heat pump.

The outlet of the condensation water pipe must be at frost free depth.

# Gutter drainage



## NOTE

Bend the hose to create a water seal, see illustration.

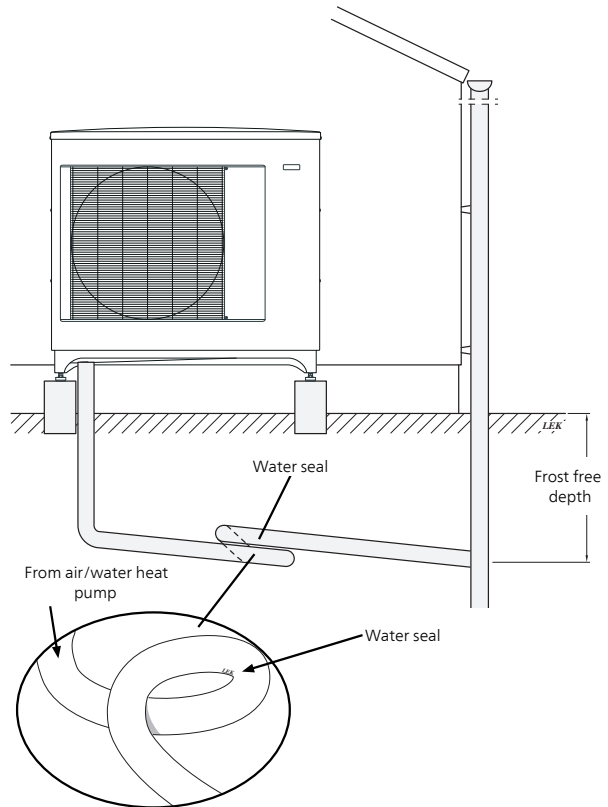

- The outlet of the condensation water pipe must be at frost free depth.
- Route the pipe downward from the air/water heat pump.
- The condensation water pipe must have a water seal to prevent air circulation in the pipe.
- The installation length can be adjusted by the size of the water seal.

# 3 Electrical connection



## NOTE

All electrical connections must be carried out by an authorised electrician.

## ELECTRICAL CONNECTION

Connect external heating cable (EB14) to terminal block X3:1 and 4 as illustrated below:

## F2016 / F2026

F2016 / F2026 is equipped with a terminal block (X3) for a heating cable. The connection is fitted with a 250 mA fuse at the factory.

### FUSE LOCATION

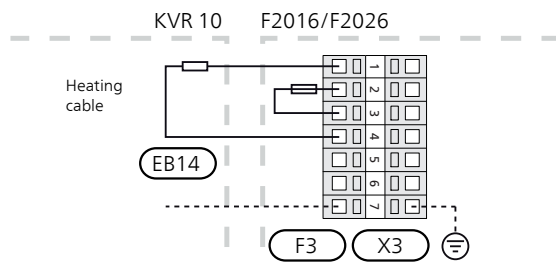
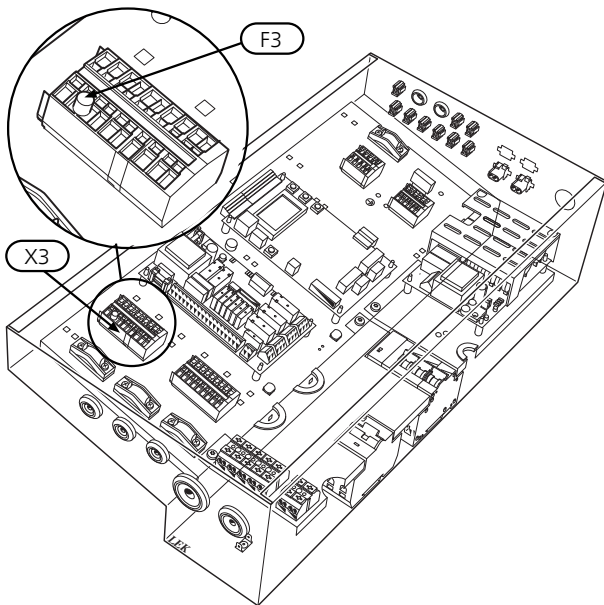

### Fuse

Length, heating cable (m)	$P_{tot}$ (W)	Fuse (F3)	Part No.
1	15	T100mA/250V	718 085
3	45	T250mA/250V	518 900*
6	90	T500mA/250V	718 086

\*Fitted at the factory.



## Cable routing

The following image shows the recommended cable routing from distribution box to condensate drain pan in F2016 / F2026. Transition between electrical cable and heating cable must be as illustrated.

1. Remove cover.
2. Thread hose clamp on.
3. Route the heating cable through the condensation water pipe.
4. Remove the condensation water trough.
5. Route the heating cable through the drain pipe and lead-in.
6. Pull the insulation down slightly, connect the hose to the drain pipe and tighten the hose clamp.
7. Push the insulation up towards the trough and install it using cable ties.
8. Lay the heating cable so that the marking is as close to the drain pipe as possible.
9. Route the cable to the distribution box as illustrated. (Extend the cable so that removal of the condensation water trough is possible, i.e. with some margin.)
10. Use factory fitted cable tie.
11. The distance between the distribution box and the lead-in to the condensation water trough is approx. 2,000 mm.
12. The length of the non heat conducting section of the cable needs adjusting. Roll the cable to the correct length (do not cut).
13. Connect the cable according to the "Electrical connection" image. (Check fuse according to table. See Fuse page 10.)
14. Reinstall the condensation water trough and cover.

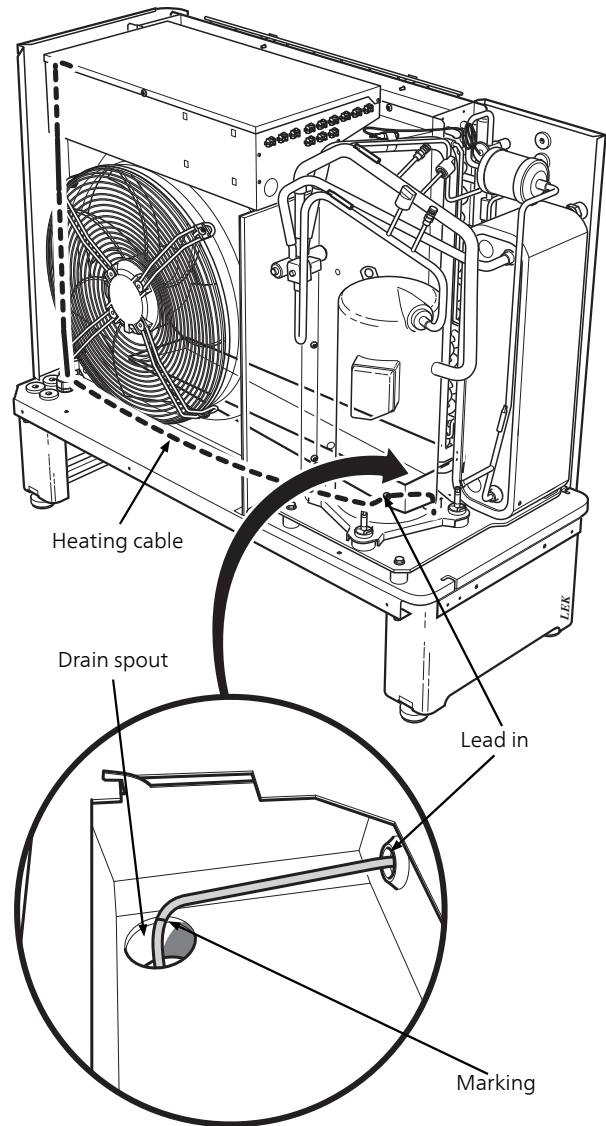

### NOTE

Ensure that the marking on the cable is edge to edge with the drain (see image).



### NOTE

Do not cut the heating cable!

# F2030 / F2300

F2030 / F2300 is equipped with a terminal block (X3) for a heating cable. The connection is fitted with a 250 mA fuse at the factory.

## FUSE LOCATION F2030

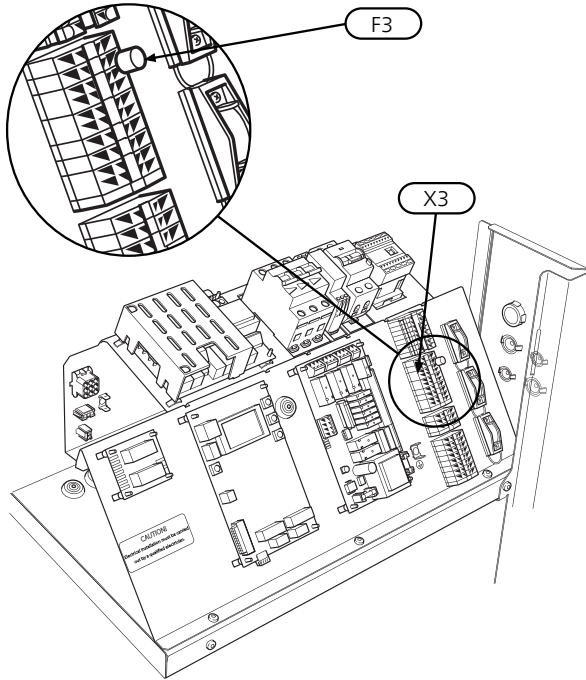

## Fuse

Length, heating cable (m)	$P_{tot}$ (W)	Fuse (F3)	Part No.
1	15	T100mA/250V	718 085
3	45	T250mA/250V	518 900*
6	90	T500mA/250V	718 086

\*Fitted at the factory.

## ELECTRICAL CONNECTION

Connect external heating cable (EB14) to terminal block X3:4 and 7 as illustrated below:

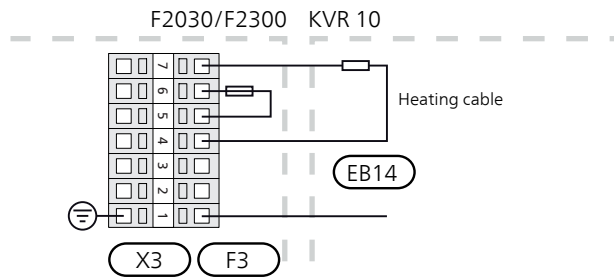

## Fuse

Length, heating cable (m)	$P_{tot}$ (W)	Fuse (F3)	Part No.
1	15	T100mA/250V	718 085
3	45	T250mA/250V	518 900*
6	90	T500mA/250V	718 086

\*Fitted at the factory.

## FUSE LOCATION F2300

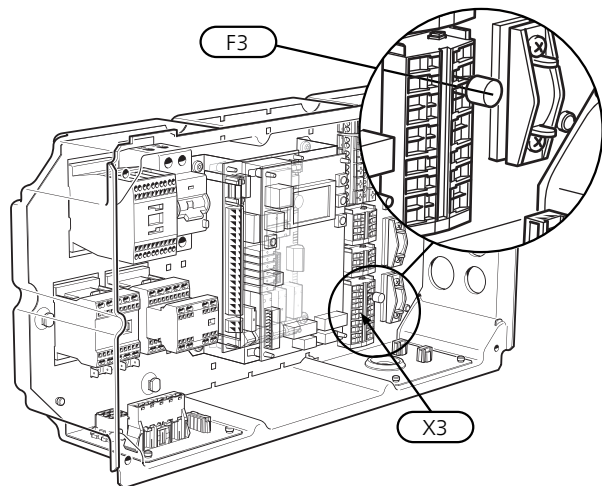

## Cable routing

The following image shows recommended cable routing from distribution box to condensation water trough in F2030/F2300.. Transition between electrical cable and heating cable must occur according to image.

1. Remove side panel.
2. Thread hose clamp on.
3. Route the heating cable through the condensation water pipe.
4. Remove the condensation water trough.
5. Route the heating cable through the drain pipe and lead-in.
6. Pull the insulation down slightly, connect the hose to the drain pipe and tighten the hose clamp.
7. Push the insulation up towards the trough and install it using cable ties.
8. Reinstall condensation water trough.
9. Stretch the heating cable so that the mark is as illustrated.
10. Route the cable to the distribution box as illustrated. (Extend the cable so that removal of the condensation water trough is possible, i.e. with some margin.)
11. Use cable ties to secure the heating cable.
12. The distance between the distribution box and the lead-in to the condensation water trough is approx. 2,600 mm.
13. Connect the cable according to the "Electrical connection" image. (Check fuse according to table. See Fuse page 10.)
14. Reinstall side panel.

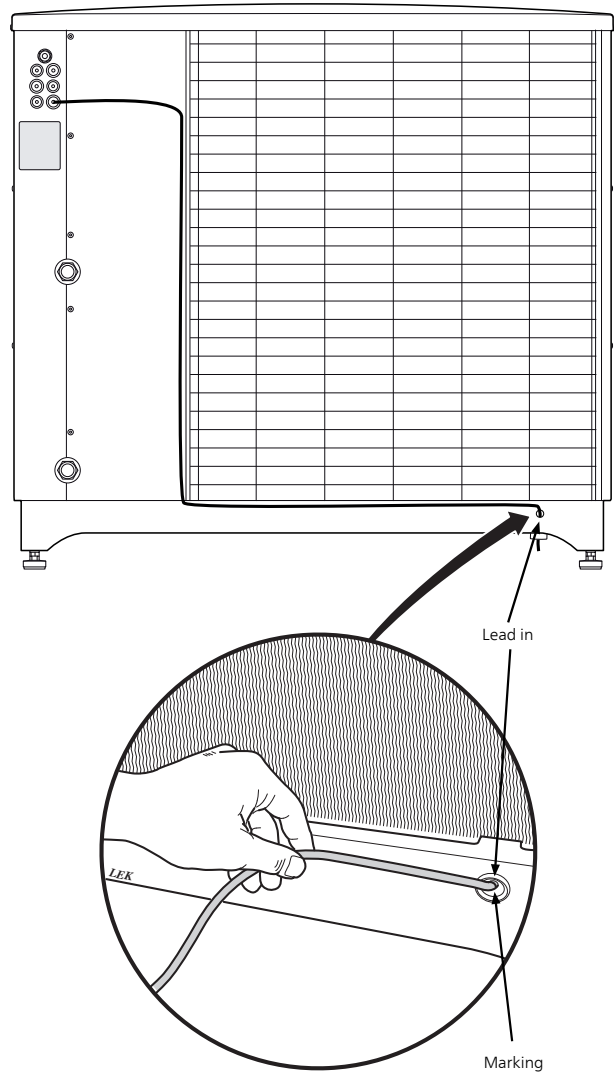

# F2040

KVR 10 is connected to the communication board AA23-X1:4-6 in F2040. Communication board (AA23) is fitted with a 250 mA fuse.

## FUSE LOCATION

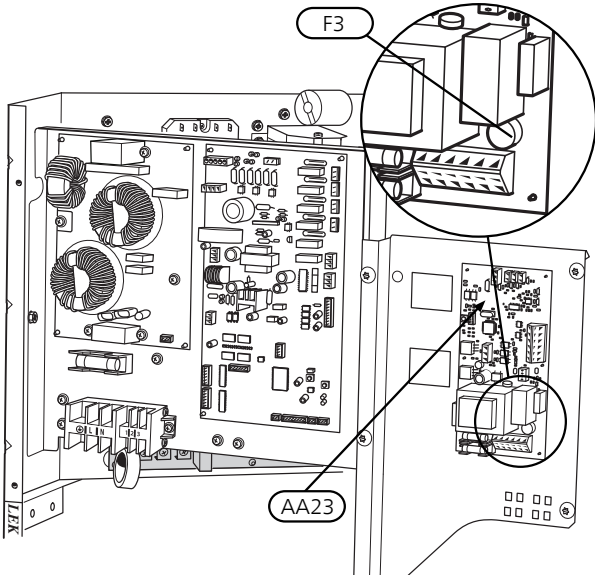

## Fuse

Length, heating cable (m)	$P_{tot}$ (W)	Fuse (F3)	Part No.
1	15	T100mA/250V	718 085
3	45	T250mA/250V	518 900*
6	90	T500mA/250V	718 086

\*Fitted at the factory.

## ELECTRICAL CONNECTION

The external heating cable (EB14) is connected to terminal block (X1:4-6) as illustrated below:

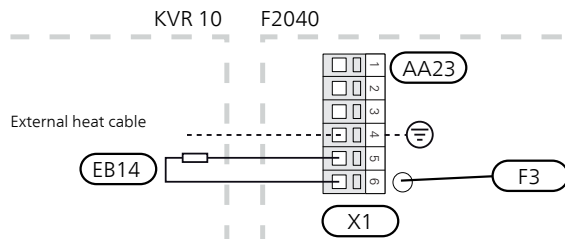

## F2040-6

Connection of residual current device RCD (FB1) between control board (PWB1) and communication board (AA23-X1:1-3).

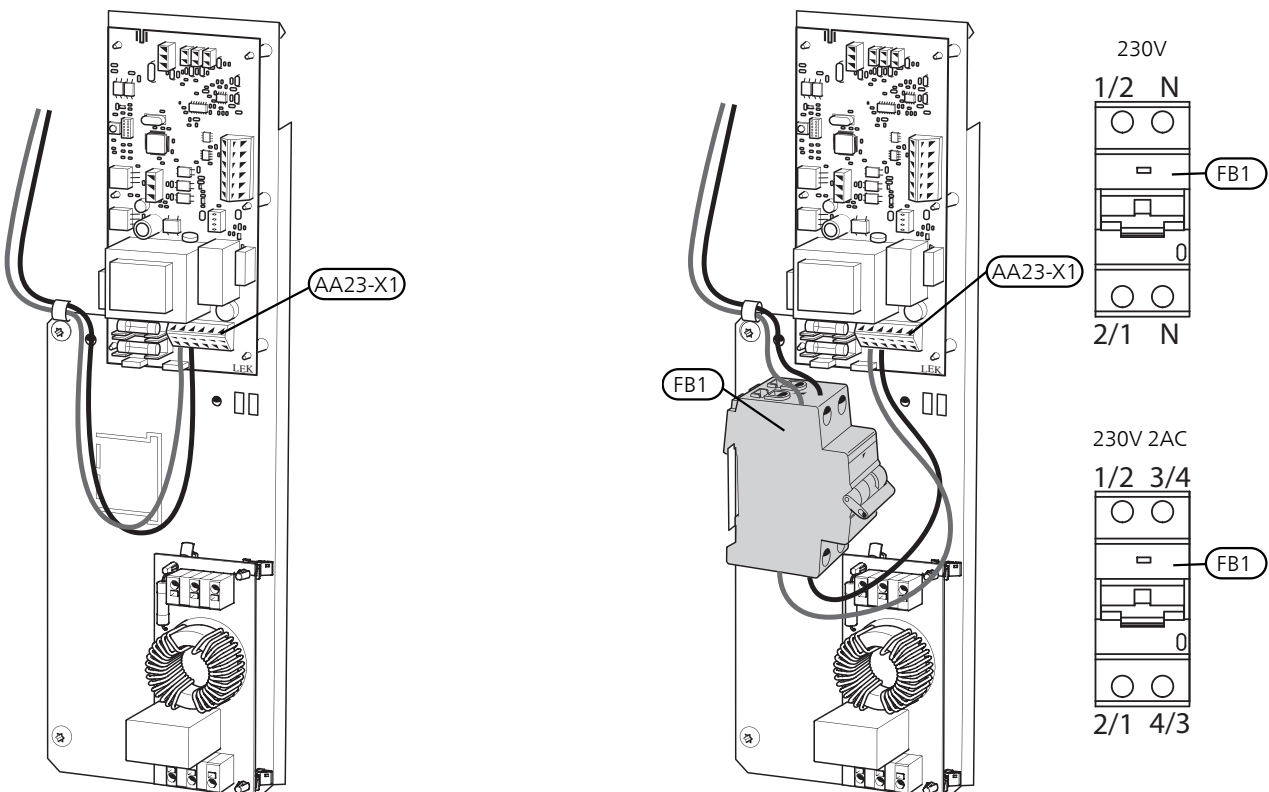

# F2040-8

Connection of residual current device RCD (FB1) between control board (PWB1) and communication board (AA23-X1:1-3).

230V/230V 2 AC

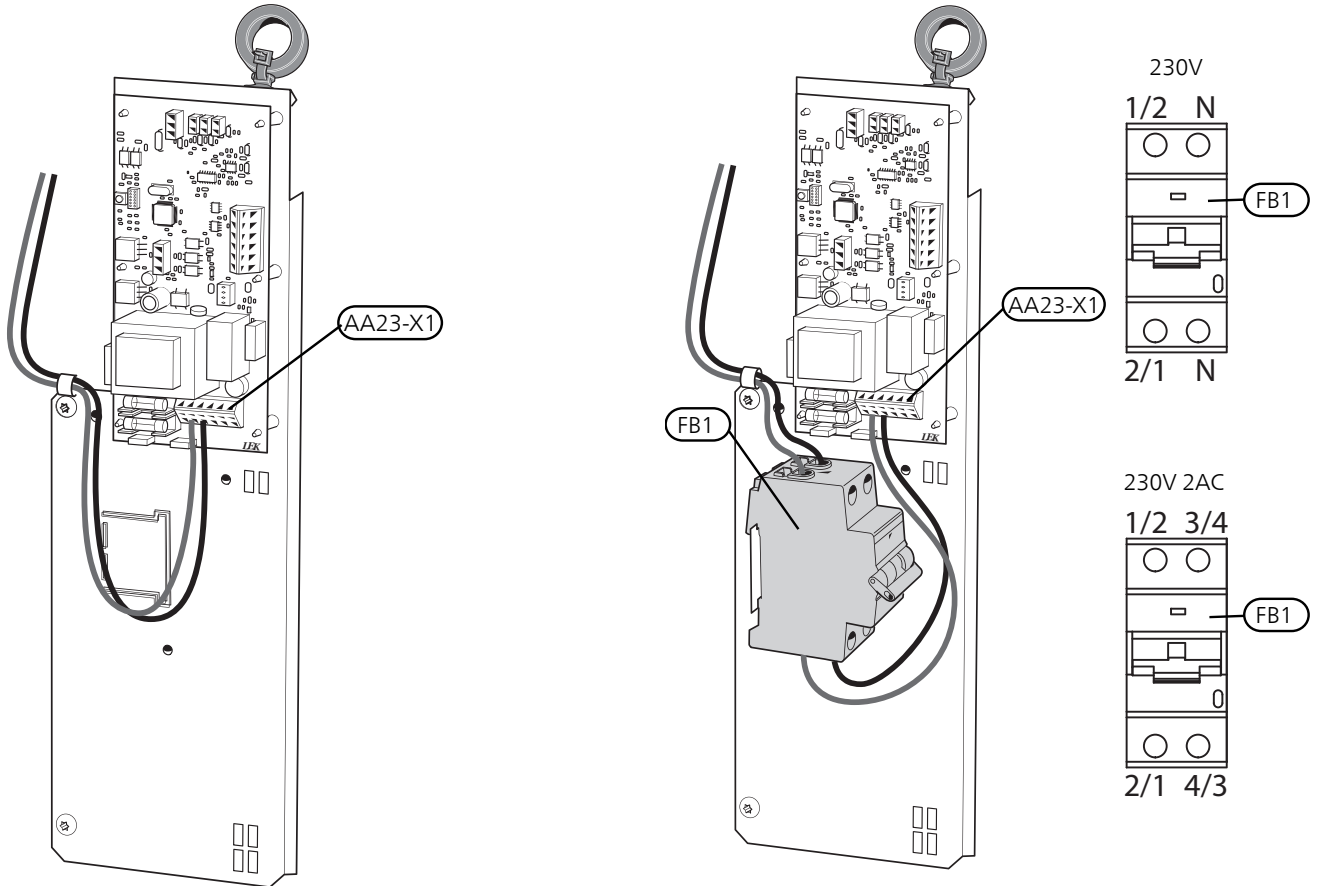

F2040-12, version 1

Connection of earth leakage circuit breaker (FB1) between terminal block (X1) and communication board (AA23-X1:1-3).

230V/230V 2 AC

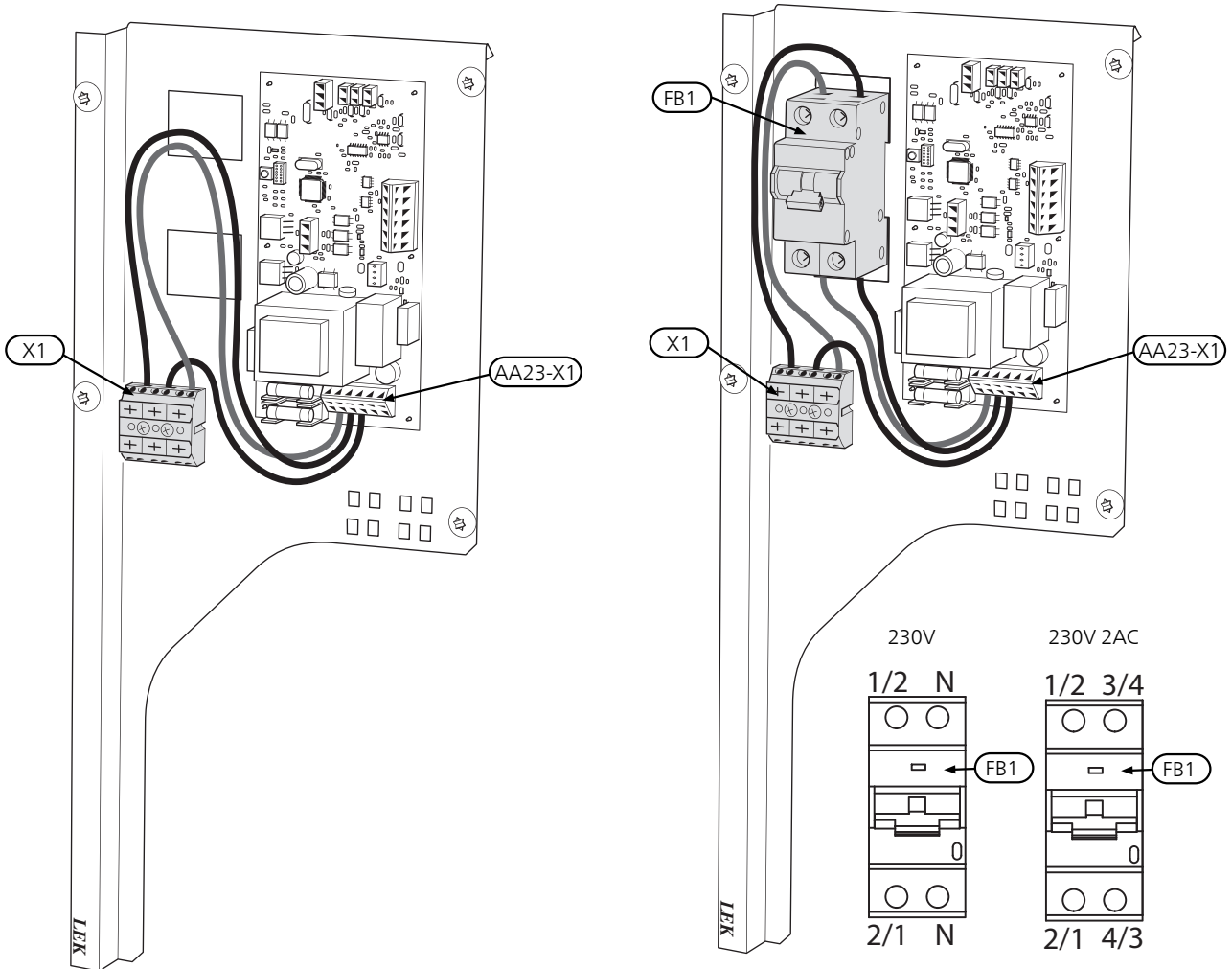

F2040-12, version 2

Connection of residual current device RCD (FB1) between control board (PWB1) and communication board (AA23-X1:1-3).

230V/230V 2 AC

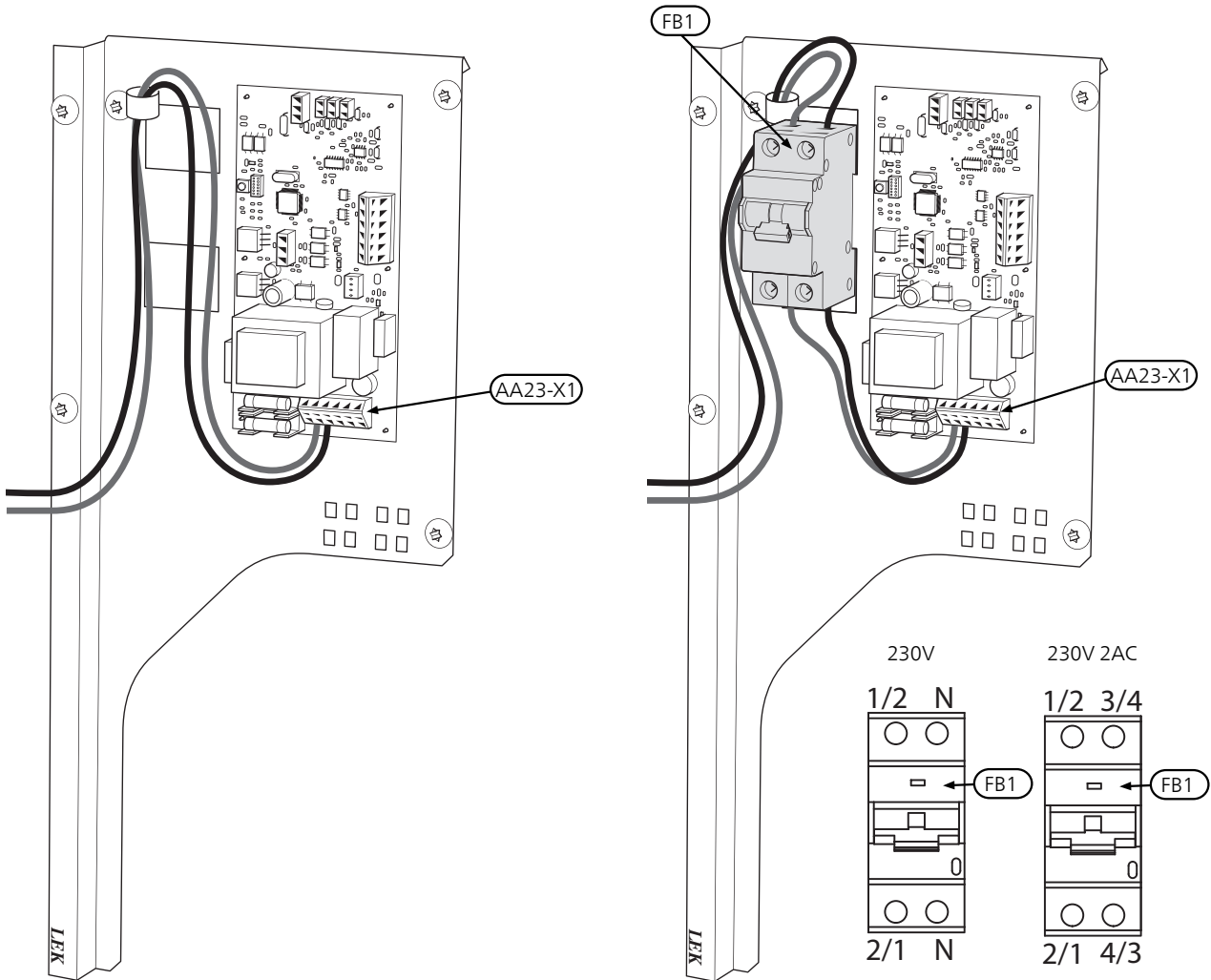

# F2040-16

Connection of residual current device RCD (FB1) between control board (PWB1) and communication board (AA23-X1:1-3).

230V/230V 2 AC

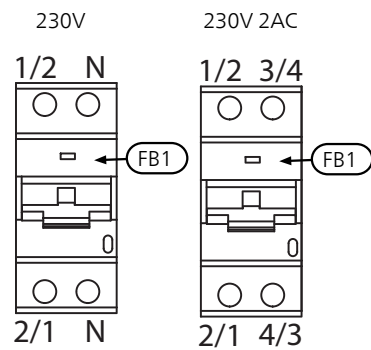
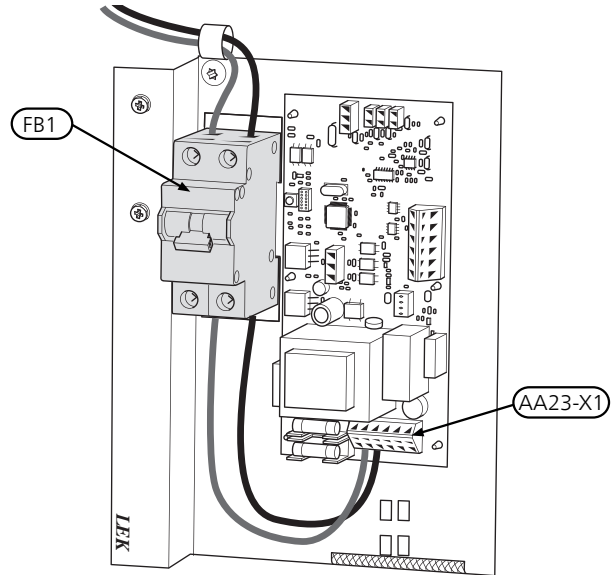
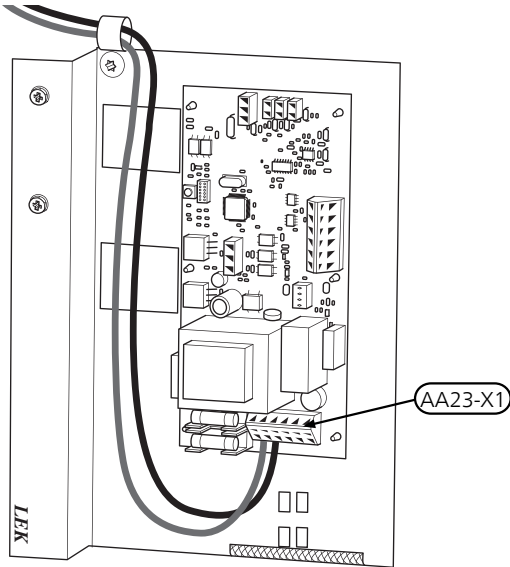



## Cable routing

The following image shows recommended cable routing from distribution box to condensation water pipe. Route the heating cable (EB14) through the grommet underneath and secure with two cable ties at the electrical connection. Transfer between electrical cable and heating cable must occur after the lead-in to the condensation water pipe.

1. Remove the front and side panels.
2. Remove the rear cover plate from the stand.

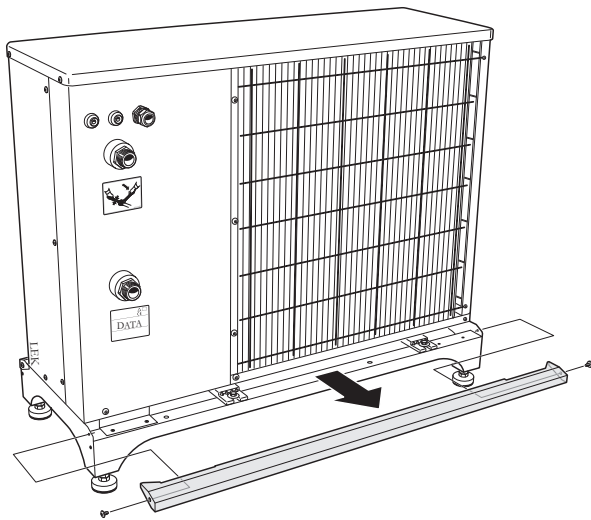

3. Pull off the protective paper and secure the gasket to the condensation water connection, see image.

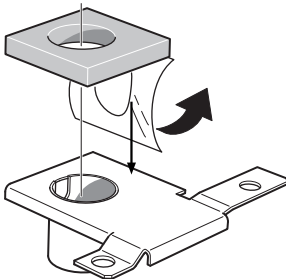

4. Thread hose clamp on.
5. Route the heating cable through the condensation water pipe.
6. Route the heating cable through the drain pipe on the connection plate, see image.

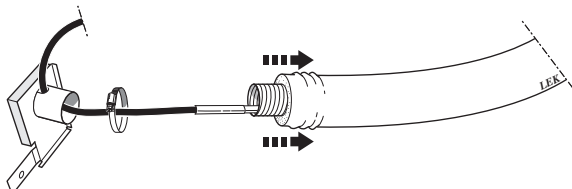

7. Pull the insulation down slightly, connect the hose to the drain pipe and tighten the hose clamp, as illustrated.

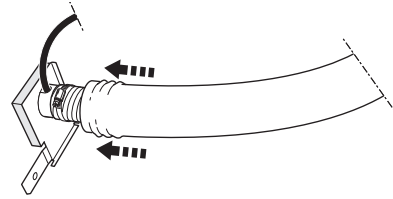

8. Push the insulation up towards the trough and secure it using cable ties, see image.

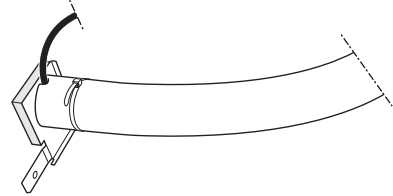

9. For F2040-6, screw the connection piece securely to the stand as illustrated using a screw and washer. Now clamp the gasket between the adapter and the bottom of the module.

For F2040-8/12/16, loosen the nut and remove the washer securing the heat pump module to the stand. Fit the holder to the module's foot and reinstall the washer and nut. Now clamp the gasket between the adapter and the bottom of the module. When the drain holes have been adjusted above each other, tighten the nut.

### F2040-6

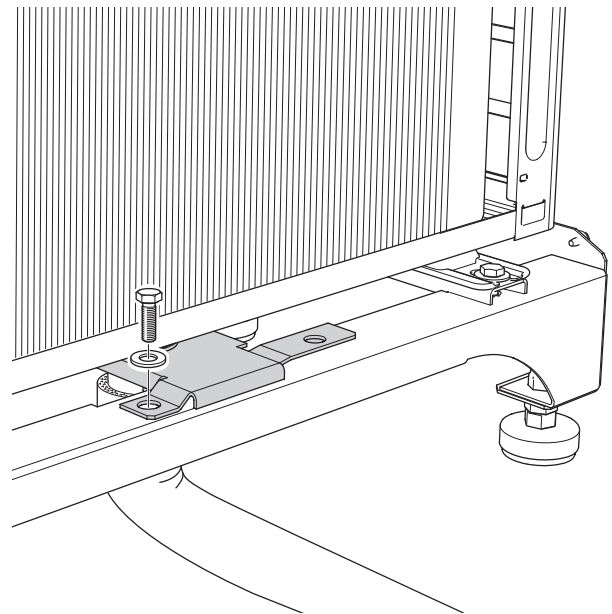

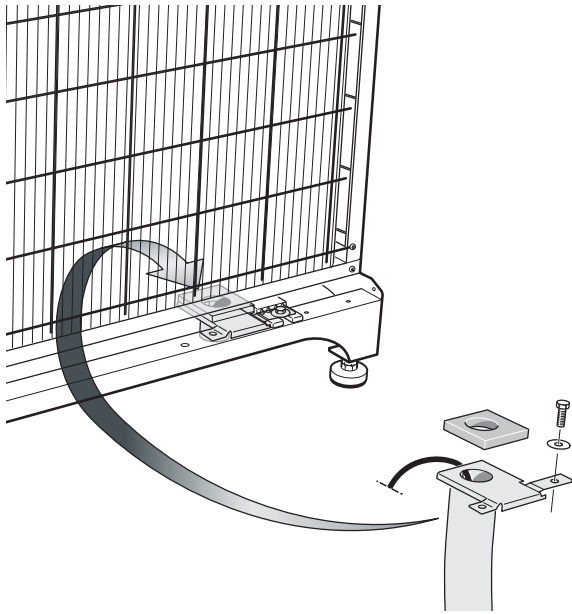

- 10. Stretch the heating cable and ensure that the marking on the heating cable is as close to the drain pipe as possible.
- 11. Route the heating cable to the electrical connection.

- 12. Use cable ties and strap anchors to secure the heating cable, see images.

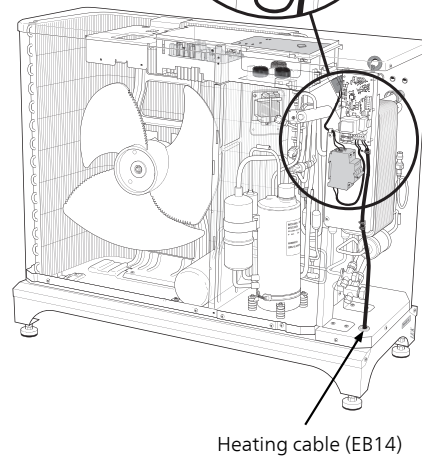
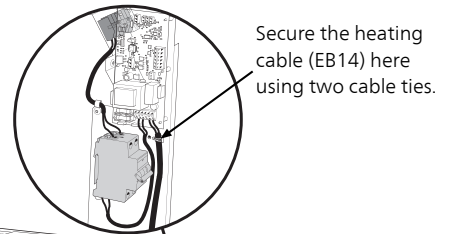
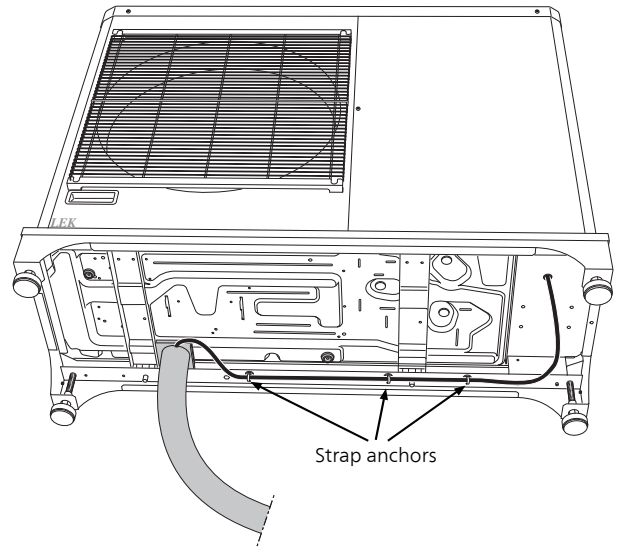

- 13. Connect the cable according to the "Electrical connection" image, see page 12. (Check the fuse according to the table, see page 12.)
- 14. Reinstall the cover, front and side panels.

15. Install plugs, see image.

2040-6

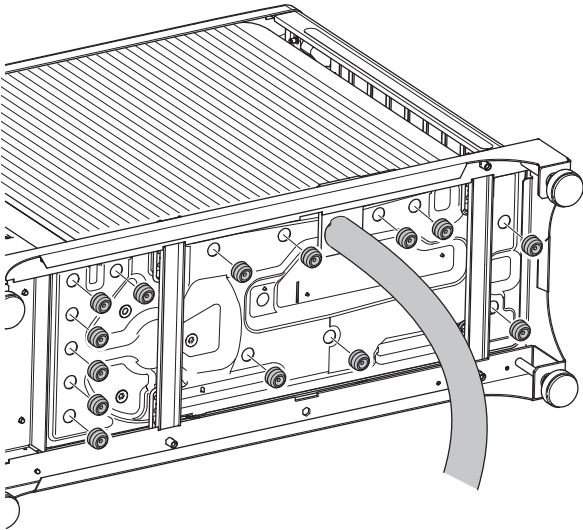

2040-8, 2040-12, 2040-16

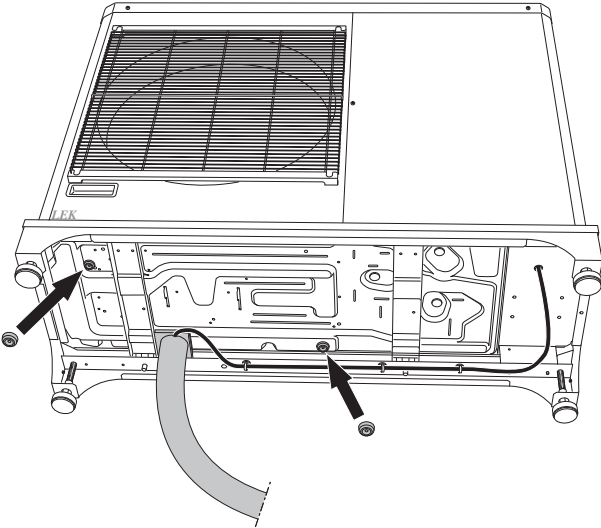

# F2120

KVR 10 is connected to the base board AA2-X9 in F2120. The connection is fused with 250 mA via fuse F3 at the factory.

## FUSE LOCATION

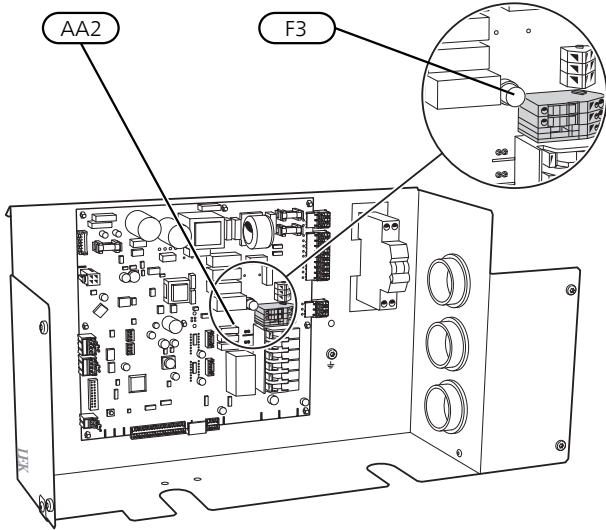

## Fuse

Length, heating cable (m)	$P_{tot}$ (W)	Fuse (F3)	Part No.
1	15	T100mA/250V	718 085
3	45	T250mA/250V	518 900*
6	90	T500mA/250V	718 086

\*Fitted at the factory.

## ELECTRICAL CONNECTION

F2120 is equipped with a terminal block for a heating cable (EB14). The connection is fused with 250 mA (F3) at the factory. If another cable is to be used, the fuse must be replaced with a suitable one.

Connect external heating cable (EB14) to terminal block X9:L and X9:N. The earth cable must be connected to X9:PE. See following image.

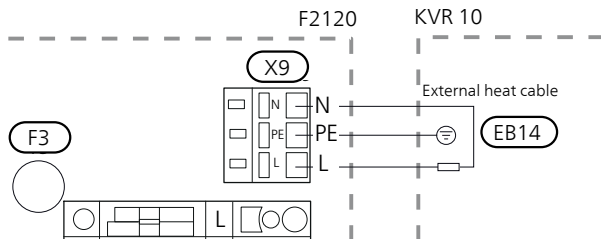

## Connecting automatic protection

Replace miniature circuit breaker (FC1) with automatic protection (FB1) if installing KVR 10. Automatic protection (FB1) is available as enclosed component for KVR 10.

Connection of automatic protection (FB1) is with -XJ4 in pos. -AA2:X4 and -XJ3 in pos. -AA2:X3.

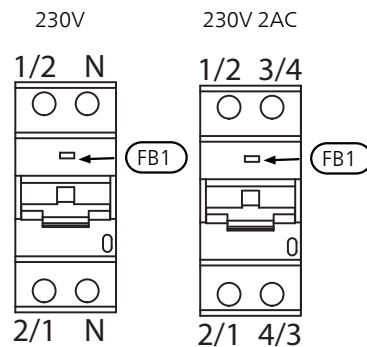
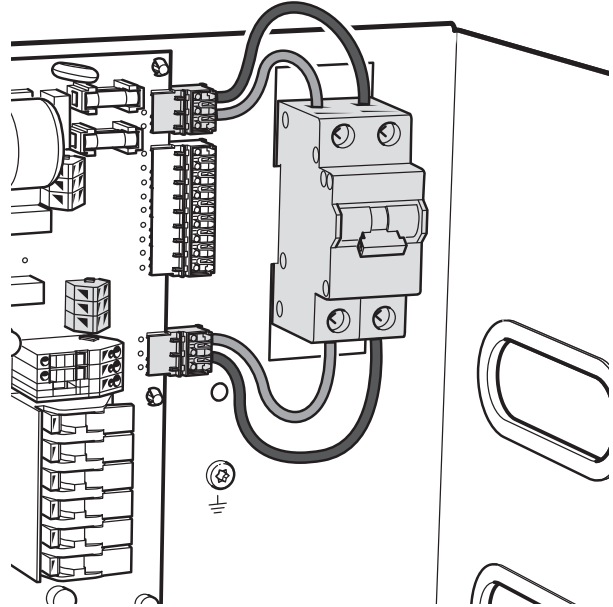

## Cable routing

The following image shows recommended cable routing from the distribution box to the condensation water trough on the inside of F2120. The transition between the electrical cable and the heating cable must occur after the lead-in to the condensation water trough. The distance between the distribution box and the lead-in to the condensation water trough is approx. 1,600 mm.

1. Remove the top and side panels.

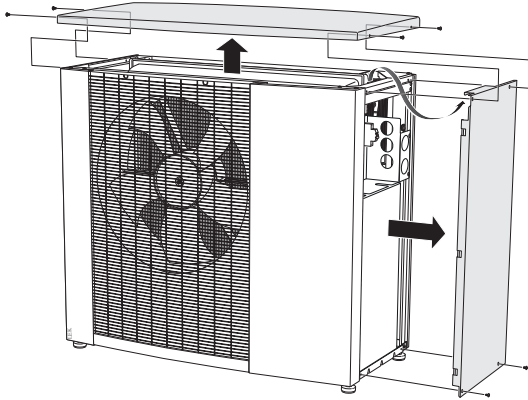

2. Thread hose clamp on.
3. Route the heating cable through the condensation water pipe.
4. Route the heating cable through the drain pipe on the reverse of KVR 10. Press the insulation down slightly.

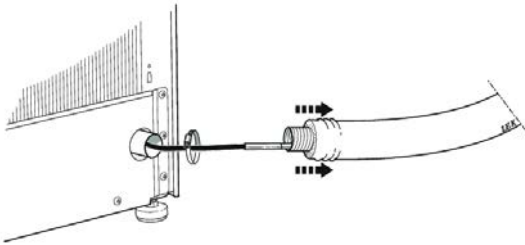

5. Connect the hose to the drain pipe and tighten the hose clamps. Pull the insulation towards the panel.

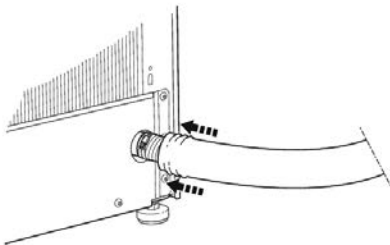

6. Secure the insulation with a cable tie.

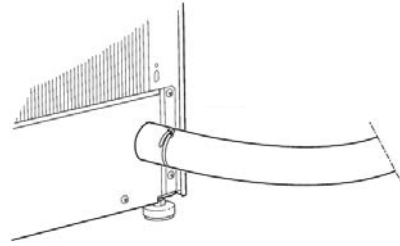

7. Stretch the heating cable and ensure that the marking on the heating cable is as close to the drain pipe as possible.
8. Route the heating cable to the electrical connection.
9. Use cable ties and strap anchors to secure the heating cable, see images.

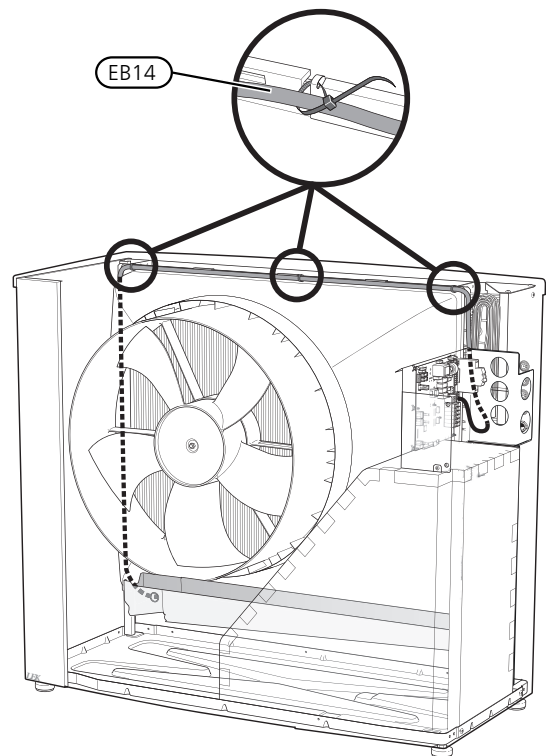

10. Connect the cable as illustrated by "Electrical connection", see page 20. (Check the fuse according to the table, see page 20).

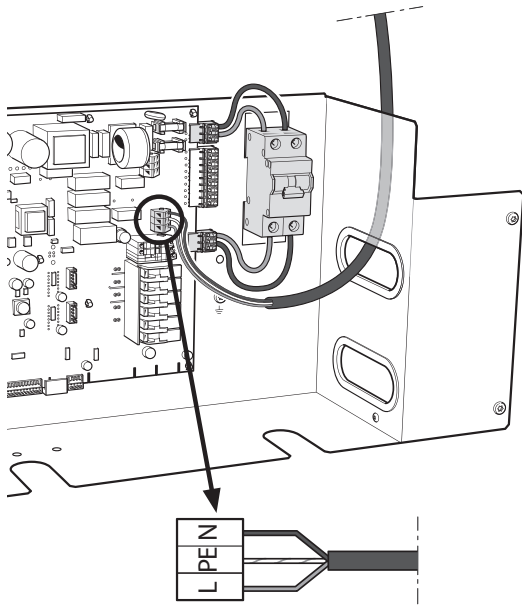

11. Reinstall the side and top panels.

# NIBE SPLIT HBS 05 / HBS 20

## FUSE LOCATION, HBS 05 / HBS 20

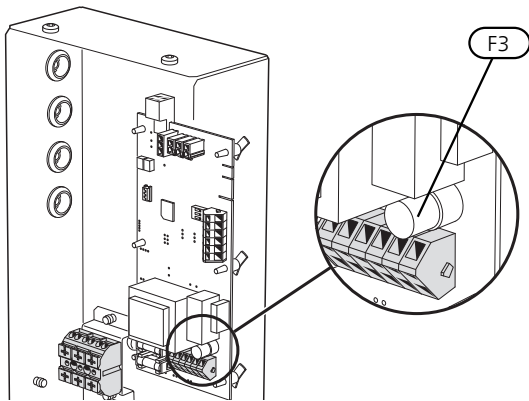

### Fuse

Length, heating cable (m)	$P_{tot}$ (W)	Fuse (F3)	Part No.
1	15	T100mA/250V	718 085
3	45	T250mA/250V	518 900*
6	90	T500mA/250V	718 086

\*Fitted at the factory.

## ELECTRICAL CONNECTION

HBS 05 / HBS 20 is equipped with a terminal block for a heating cable (EB14). The connection is fused with 250 mA (F3 on the communication board AA23). If another cable is to be used, the fuse must be replaced with a suitable one (see table).

Connect external heating cable (EB14) to terminal block AA23-X1:4–6 according to following image:

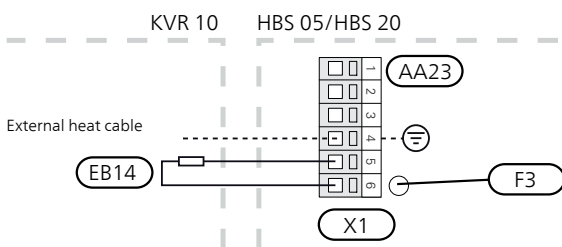

## Connecting automatic protection

Connection of earth leakage circuit breaker (FB1) between terminal block (X1) and communication board (AA23-X1:1-3). Cut off the brown and blue cores. Connect the brown core connected to X1:L1 to the automatic protection FB1:1/2 and the blue core connected to X1:N to FB1:N. The brown core that is connected to AA23-X1:1 must be connected to the automatic protection FB1:2/1 and the blue core connected to AA23-X1:2 must be connected to FB1:N.

Strip 11 mm from cores that are to be connected to the automatic protection.

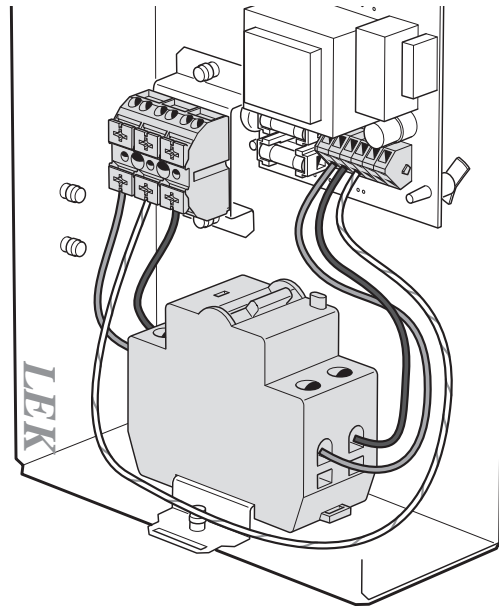



## CABLE ROUTING, AMS 10 / AMS 20

Recommended cable routing from the junction box up to the condensation water hose connection to AMS 10 / AMS 20. There is a transition between the cold and hot sections of the heating cable at the marking on the cable. The marking should end up edge to edge with the hole for the cable grommet.

1. Pull off the protective paper and secure the gasket to the condensation water connection, see image.

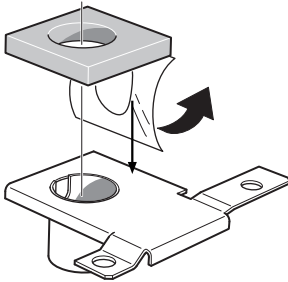

2. Thread hose clamp on.
3. Route the heating cable through the condensation water pipe.
4. Route the heating cable through the drain pipe on the connection plate, see image.

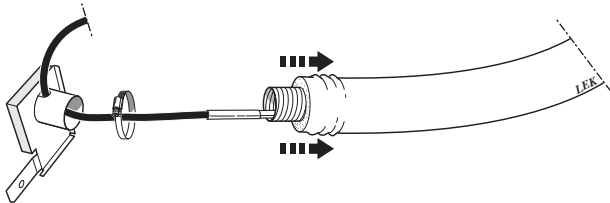

5. Pull the insulation down slightly, connect the hose to the drain pipe and tighten the hose clamps, see image.

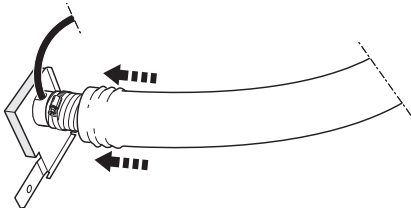

6. Push the insulation up towards the trough and secure it using cable ties, see image.

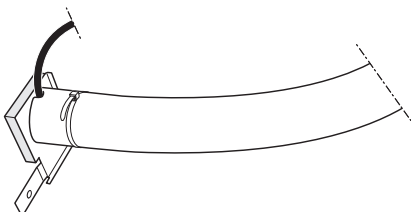

7. Stretch the heating cable and ensure that the marking on the heating cable is as close to the drain pipe as possible.

8. Install the connection plate on AMS 10 / AMS 20. Use the mounting bolt that is securing the heat pump. (See image of relevant AMS 10 / AMS 20 model.)

AMS 10-6

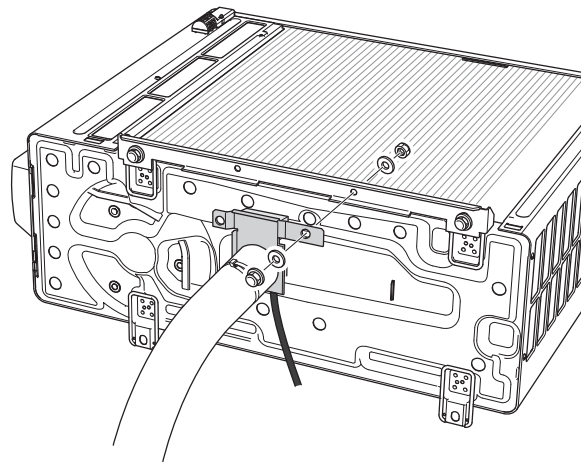
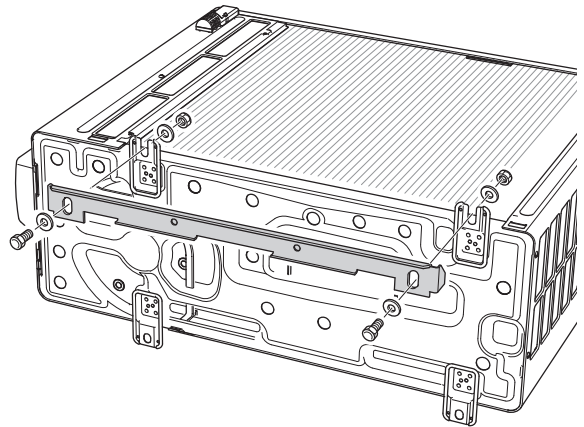



AMS 20-6

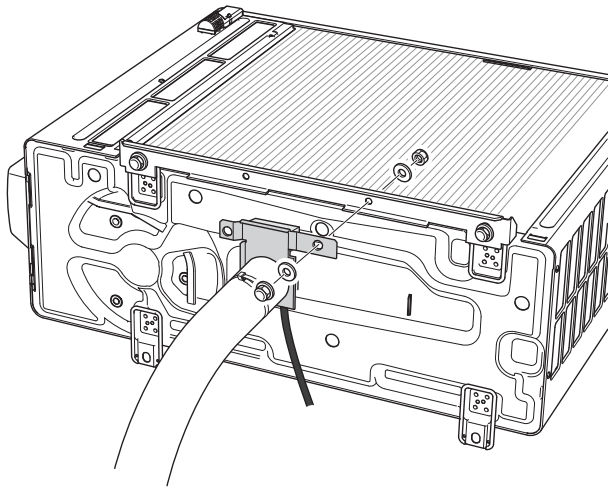
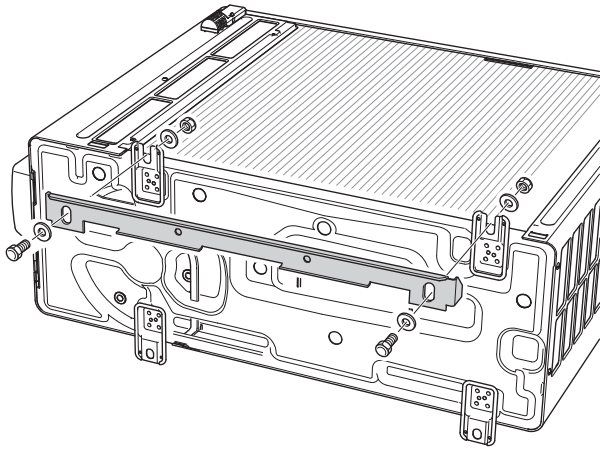

AMS 10-8

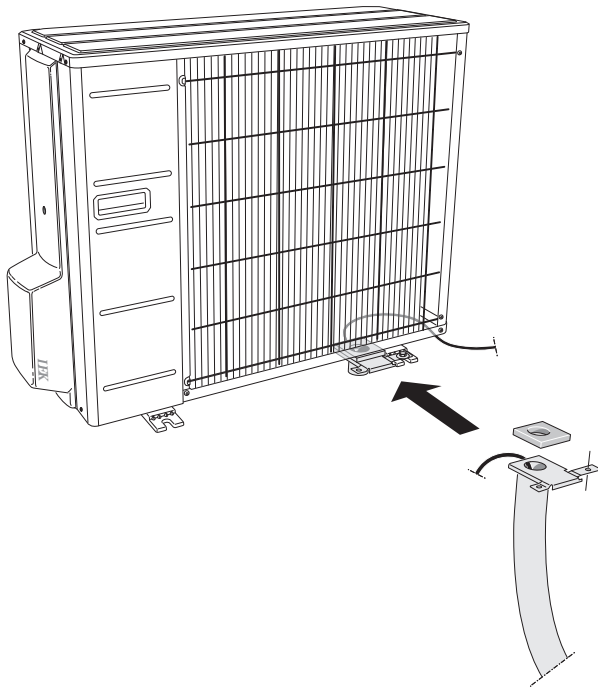

AMS 10-12

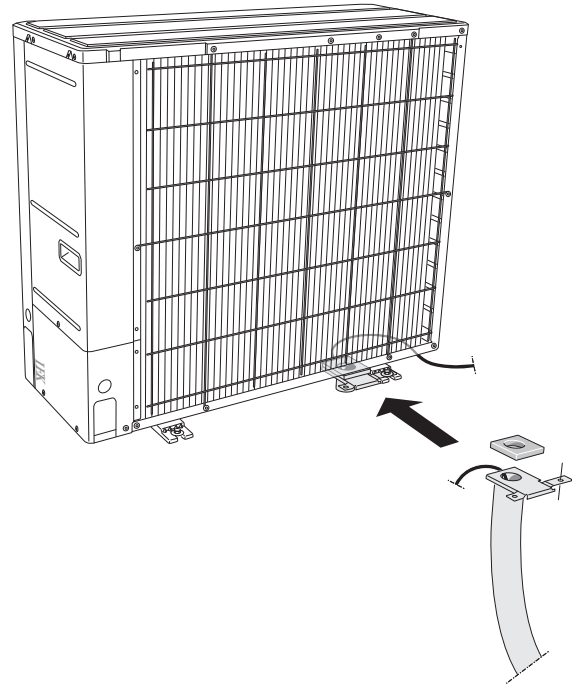

AMS 10-16

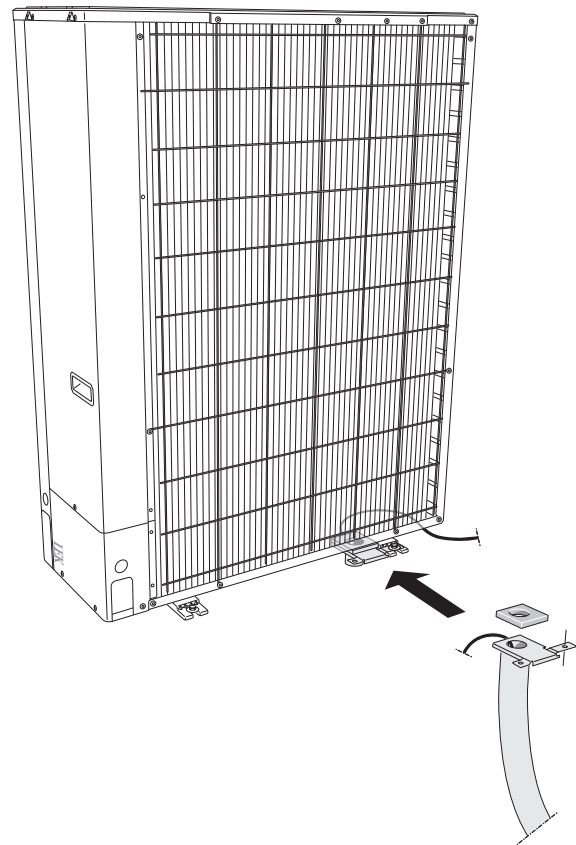

- Install plugs on the underside of AMS 10 / AMS 20. (See image of relevant model.)

AMS 10-6

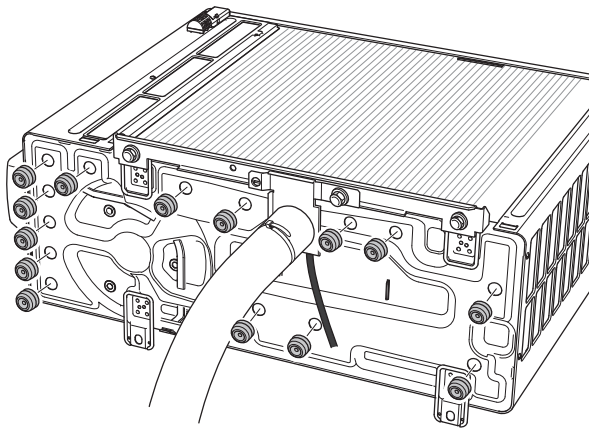

AMS 10-12

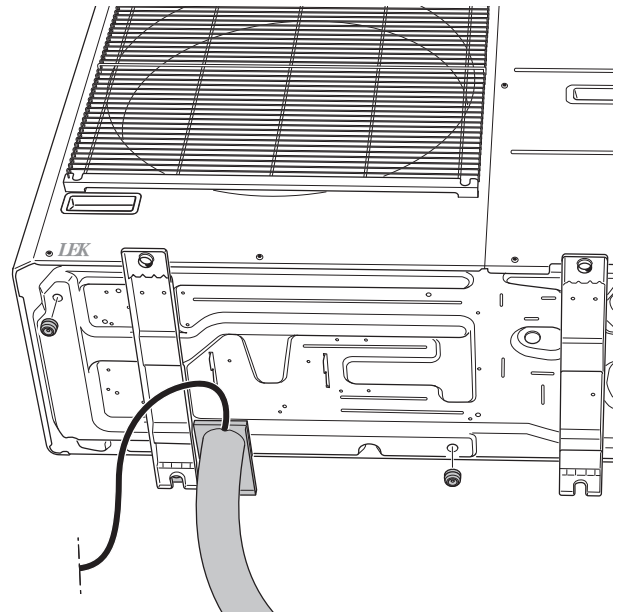

AMS 20-6

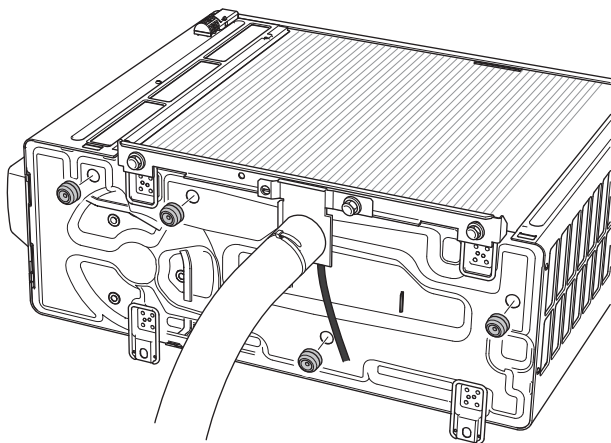

AMS 10-16

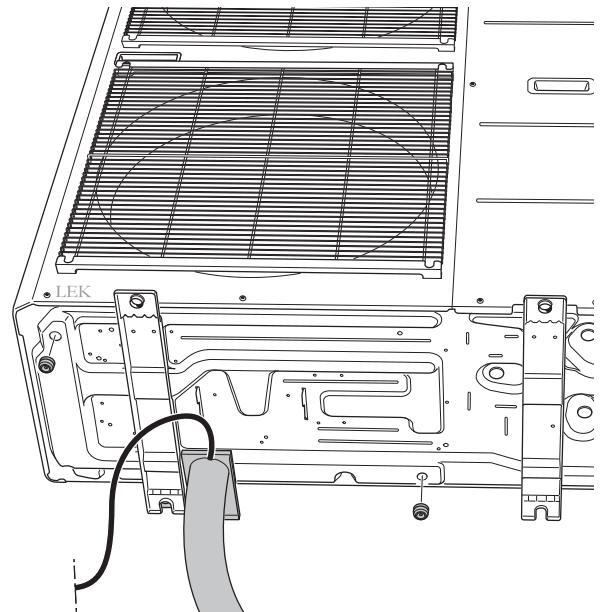

AMS 10-8

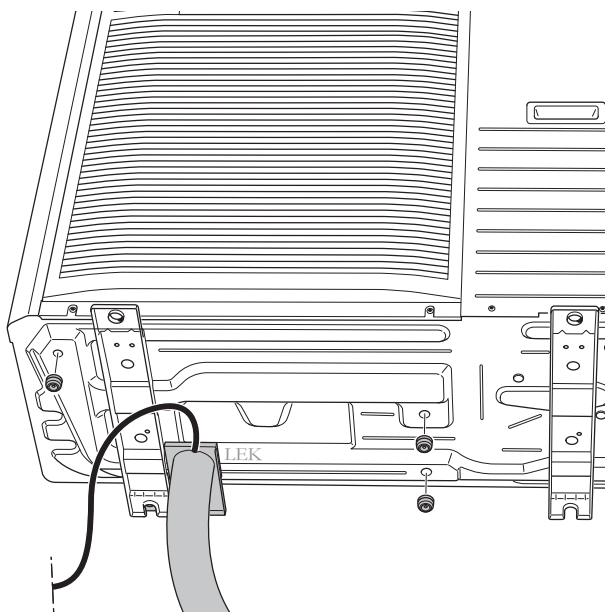

- Mount the junction box on the wall close to AMS 10 / AMS 20.

11. Route the heating cable to the junction box and connect it to the cable from the electrical connection HBS 05 / HBS 20, as illustrated in "Electrical connection".

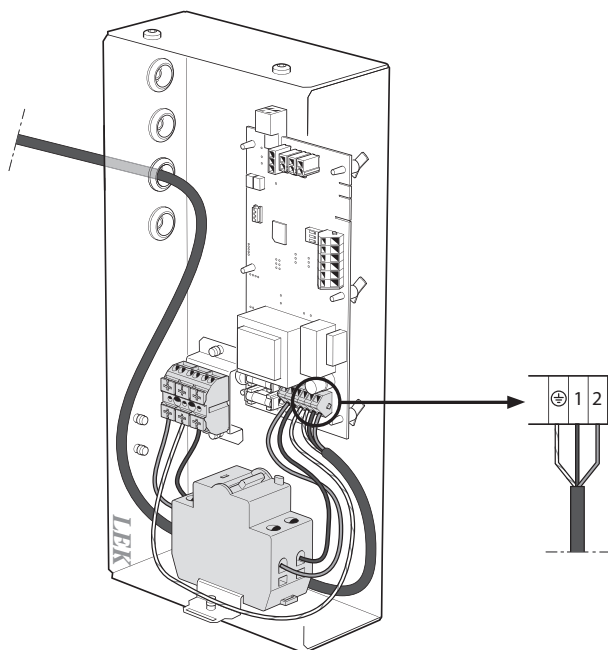

The figure shows the connection in HBS 05 / HBS 20.







## Contact information

### *AUSTRIA*

KNV Energietechnik GmbH  
Gahberggasse 11, 4861 Schörfling  
Tel: +43 (0)7662 8963-0  
mail@knv.at  
knv.at

### *CZECH REPUBLIC*

Družstevní závody Dražice - strojírna  
s.r.o.  
Dražice 69, 29471 Benátky n. Jiz.  
Tel: +420 326 373 801  
nibe@nibe.cz  
nibe.cz

### *DENMARK*

Vølund Varmeteknik A/S  
Industrivej Nord 7B, 7400 Herning  
Tel: +45 97 17 20 33  
info@volundvt.dk  
volundvt.dk

### *FINLAND*

NIBE Energy Systems Oy  
Juurakkotie 3, 01510 Vantaa  
Tel: +358 (0)9 274 6970  
info@nibe.fi  
nibe.fi

### *FRANCE*

NIBE Energy Systems France SAS  
Zone industrielle RD 28  
Rue du Pou du Ciel, 01600 Reyrieux  
Tél: 04 74 00 92 92  
info@nibe.fr  
nibe.fr

### *GERMANY*

NIBE Systemtechnik GmbH  
Am Reiherpfahl 3, 29223 Celle  
Tel: +49 (0)5141 75 46 -0  
info@nibe.de  
nibe.de

### *GREAT BRITAIN*

NIBE Energy Systems Ltd  
3C Broom Business Park,  
Bridge Way, S41 9QG Chesterfield  
Tel: +44 (0)845 095 1200  
info@nibe.co.uk  
nibe.co.uk

### *NETHERLANDS*

NIBE Energietechnik B.V.  
Energieweg 31, 4906 CG Oosterhout  
Tel: +31 (0)168 47 77 22  
info@nibenl.nl  
nibenl.nl

### *NORWAY*

ABK-Qviller AS  
Brobekkveien 80, 0582 Oslo  
Tel: (+47) 23 17 05 20  
post@abkqviller.no  
nibe.no

### *POLAND*

NIBE-BIAWAR Sp. z o.o.  
Al. Jana Pawla II 57, 15-703 Bialystok  
Tel: +48 (0)85 66 28 490  
biawar.com.pl

### *RUSSIA*

EVAN  
bld. 8, Yuliusa Fuchika str.  
603024 Nizhny Novgorod  
Tel: +7 831 419 57 06  
kuzmin@evan.ru  
nibe-evan.ru

### *SWEDEN*

NIBE Energy Systems  
Box 14  
Hannabadsvägen 5, 285 21 Markaryd  
Tel: +46 (0)433-27 3000  
info@nibe.se  
nibe.se

### *SWITZERLAND*

NIBE Wärmetechnik c/o ait Schweiz  
AG  
Industriepark, CH-6246 Altishofen  
Tel. +41 (0)58 252 21 00  
info@nibe.ch  
nibe.ch

For countries not mentioned in this list, contact NIBE Sweden or check [nibe.eu](http://nibe.eu) for more information.

NIBE Energy Systems  
Hannabadsvägen 5  
Box 14  
SE-285 21 Markaryd  
info@nibe.se  
nibe.eu

IHB EN 2024-3 431740

This manual is a publication from NIBE Energy Systems. All product illustrations, facts and data are based on the available information at the time of the publication's approval. NIBE Energy Systems makes reservations for any factual or printing errors in this manual.

©2020 NIBE ENERGY SYSTEMS

