

HRV unit NIBE GV-HR 120-400

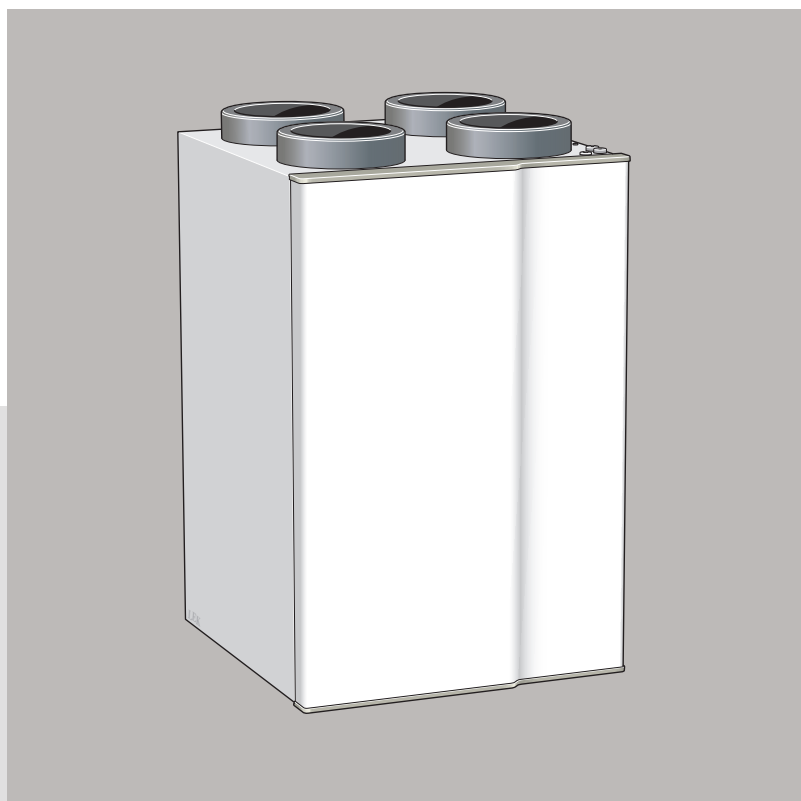

Table of Contents

1	<i>Important information</i>	4	Start-up and inspection	16
	Safety information	4		
	Symbols	4	7 <i>Control - Introduction</i>	18
	Marking	4	Display	18
	Serial number	4	Operating menu	18
	Recovery	5	Main menu	19
	Inspection of the installation	6	Menu system	20
2	<i>Delivery and handling</i>	7	8 <i>Control - Menus</i>	22
	Transport and storage	7	Date and time	22
	Supplied components	7	Calendar	22
	Removing the covers	7	User menu	22
	Removing parts of the insulation	7	Display	23
	Assembly	8	Operation info	23
	Mounting	9	Service menu	24
3	<i>Design of the HRV unit</i>	10	9 <i>Disturbances in comfort</i>	29
	Pipe connections	11	Info-menu	29
	Sensors etc.	11	Manage alarm	29
	Electrical components	11	Troubleshooting	30
	Ventilation	11	10 <i>Service</i>	31
	Miscellaneous	11	Service actions	31
4	<i>Ventilation connections</i>	12	11 <i>Accessories</i>	32
	Condensation water drain	12	12 <i>Technical data</i>	33
	General ventilation connections	13	Dimensions	33
	Ventilation flow	13	Technical specifications	34
	Adjusting ventilation	13	Energy labelling	35
	Dimensions and ventilation connections	13	Electrical circuit diagram	36
5	<i>Electrical connection</i>	14	<i>Item register</i>	37
	PCB overview (AA2)	14	<i>Contact information</i>	42
	Supply	14		
	Display	14		
	External connection options	15		
6	<i>Commissioning and adjusting</i>	16		
	Preparations	16		
	Filling	16		

1 Important information

Safety information

This manual describes installation and service procedures for implementation by specialists.

The manual must be left with the customer.

This appliance can be used by children aged from 8 years and above and persons with reduced physical, sensory or mental capabilities or lack of experience and knowledge if they have been given supervision or instruction concerning use of the appliance in a safe way and understand the hazards involved. Children shall not play with the appliance. Cleaning and user maintenance shall not be made by children without supervision.

This is an original manual. It may not be translated without the approval of NIBE. Rights to make any design or technical modifications are reserved.

©NIBE 2021.

Symbols



NOTE

This symbol indicates danger to person or machine.



Caution

This symbol indicates important information about what you should consider when installing or servicing the installation.



TIP

This symbol indicates tips on how to facilitate using the product.

Marking

CE The CE mark is obligatory for most products sold in the EU, regardless of where they are made.

IP X1B Classification of enclosure of electro-technical equipment.

Serial number

The serial number can be found at the top right inside the front hatch.

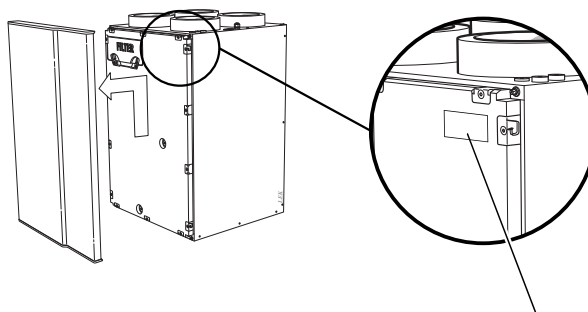

Serial number



Caution

You need the product's serial number for servicing and support.

Recovery



Leave the disposal of the packaging to the installer who installed the product or to special waste stations.

■ When disposing of the product, its constituent materials and components, e.g. compressors, fans, circulation pumps and circuit boards, must be disposed of at a special waste station or dealer who provides this type of service.

To access the separate components, refer to the section that shows the construction of the product. No special tools are required for access.

Improper disposal of the product by the user results in administrative penalties in accordance with current legislation.

Inspection of the installation

Current regulations require the heating installation to be inspected before it is commissioned. The inspection must be carried out by a suitably qualified person. In addition, fill in the page for the installation data in the User Manual.

✓	Description	Notes	Signature	Date
	Ventilation (page 13)			
	Setting ventilation flow exhaust air level 1			
	Setting ventilation flow exhaust air level 2			
	Setting ventilation flow exhaust air level 3			
	Setting ventilation flow supply air level 1			
	Setting ventilation flow supply air level 2			
	Setting ventilation flow supply air level 3			
	Electricity (page 14)			
	Connections			
	Main voltage			
	Fuses property			
	Earth circuit-breaker			

2 Delivery and handling

Transport and storage Removing the covers

GV-HR 120 should be transported and stored in the dry.

Supplied components

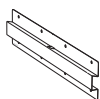

Rail for wall mounting



Display

FRONT COVER

1. Lift the front cover upwards slightly.
2. Pull the hatch towards yourself.

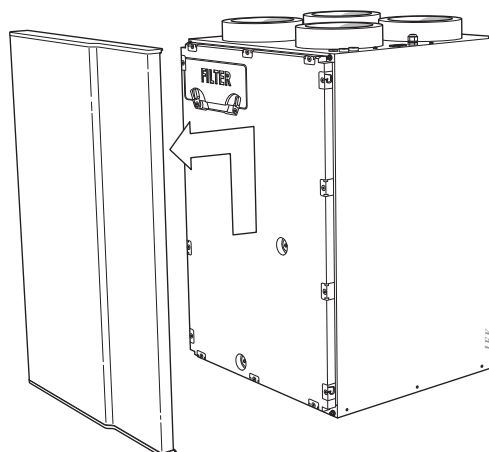

Removing parts of the insulation

FRONT INSULATION

The insulation in the front must be removed to access the internal parts.

1. Remove the air filter.

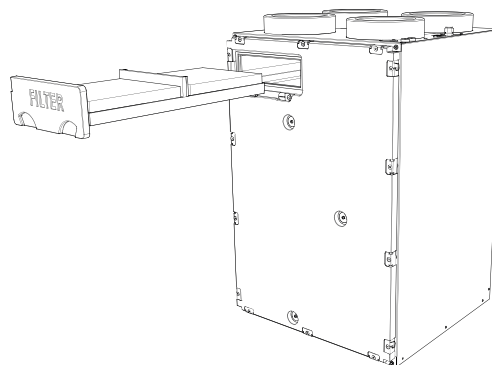

2. Slacken off the screws that hold the insulation in place.

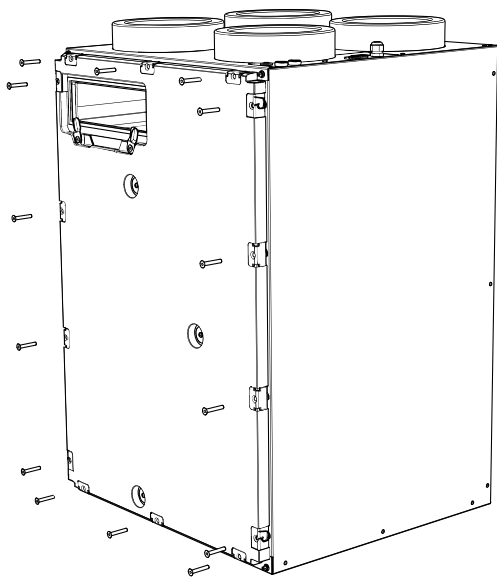

3. Pull the insulation straight out.

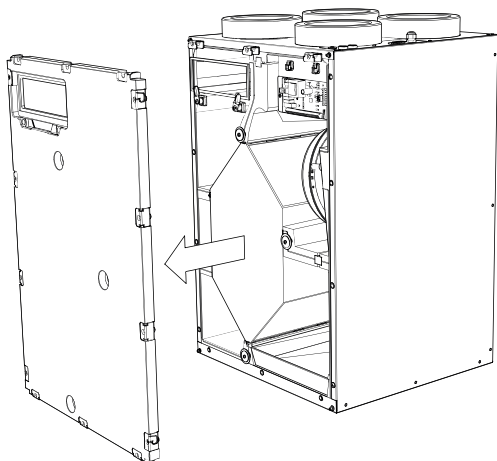

Assembly

GV-HR 120 is installed using the enclosed rail on a solid wall. Noise from the fans can be transferred to the rail.

- Install with its back to an outside wall, ideally in a room where noise does not matter, in order to eliminate noise problems. If this is not possible, avoid placing it against a wall behind a bedroom or other room where noise may be a problem.
- Wherever the unit is located, walls to sound sensitive rooms should be fitted with sound insulation.
- Condensation water comes from the HRV unit. A condensation outlet with a water seal must be installed and routed to an internal drain.
- The HRV unit's installation area always has to have a temperature of at least 10 °C and max. 35 °C.

INSTALLATION AREA

Leave a free space of 800 mm in front of the product.

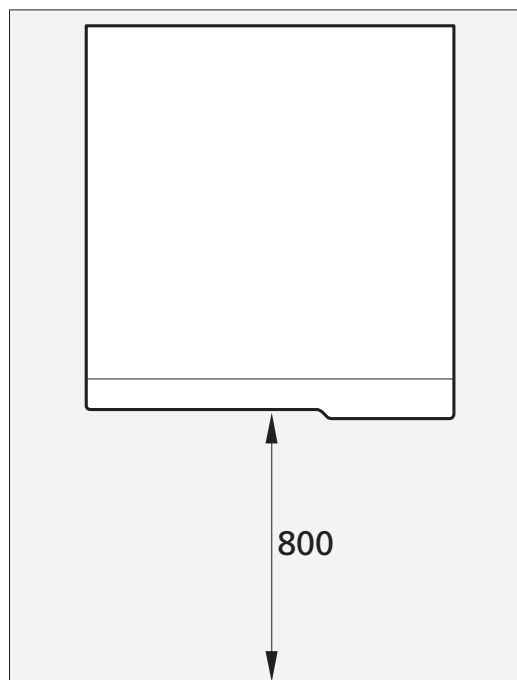

NOTE

Ensure that there is sufficient space (300 mm) above the HRV unit for installing ventilation hoses.

Mounting

When hanging on a wooden wall, a vibration damper is recommended to prevent vibration being transferred.

1. Install the enclosed bracket to the wall.
2. Install GV-HR 120 on the brackets.

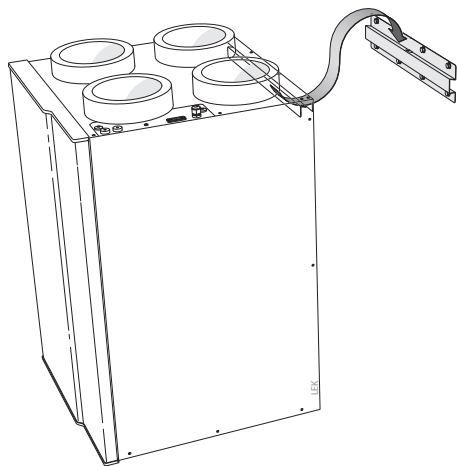

3. Screw GV-HR 120 firmly into place on the bracket.

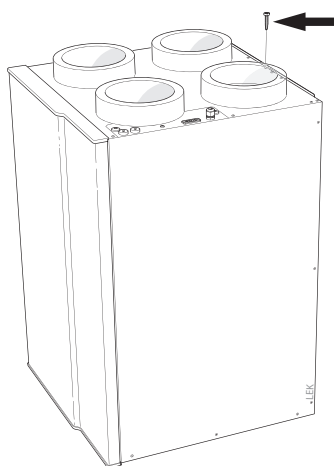

3 Design of the HRV unit

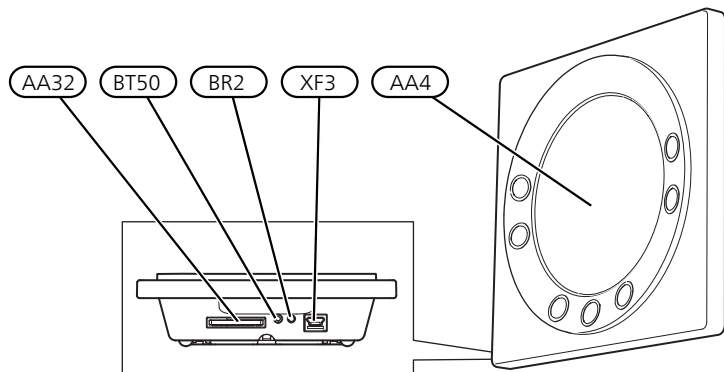
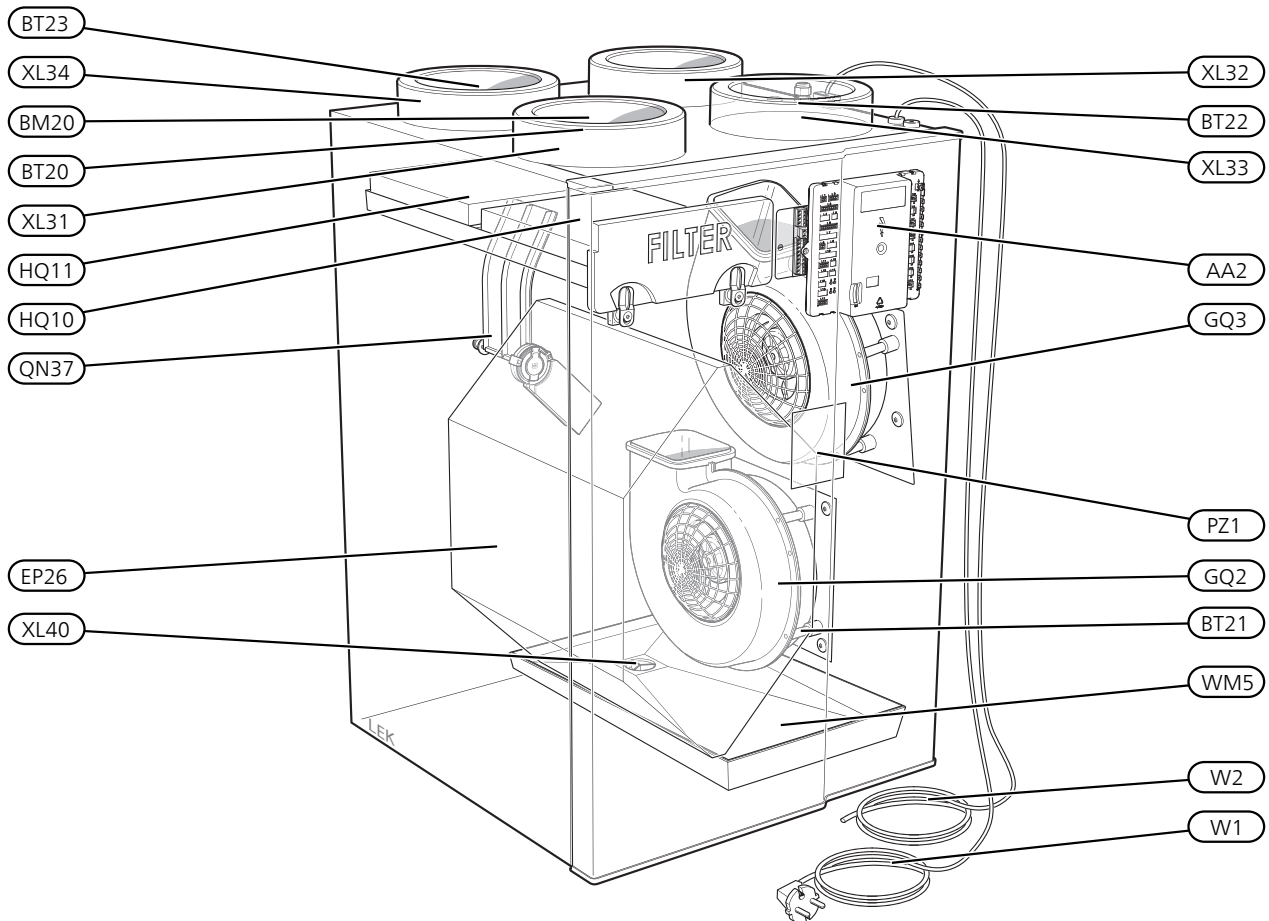

Pipe connections

XL31	Ventilation connection, exhaust air
XL32	Ventilation connection, extract air
XL33	Ventilation connection, supply air
XL34	Ventilation connection, outdoor air
XL40	Condensation water drain

Sensors etc.

BM20	Humidity sensor, exhaust air (P1)
BR2	Light sensor
BT20	Temperature sensor, exhaust air (T7)
BT21	Temperature sensor, extract air (T4)
BT22	Temperature sensor, supply air (T1)
BT23	Temperature sensor, outdoor air (T3)
BT50	Room sensor(T2)

Electrical components

AA2	Base card
AA4	Display unit
AA32	Memory card
W101	Cord with connection plug
W102	Communication cable

Ventilation

EP26	Heat exchanger
GQ2	Exhaust air fan (M1)
GQ3	Supply air fan (M2)
HQ10	Exhaust air filter
HQ11	Supply air filter
QN37	Bypass damper

Miscellaneous

PZ1	Type plate
WM5	Condensation water trough

Designations in brackets show the name of the component in the display.

Designations according to standard EN 81346-2.

4 Ventilation connections

Condensation water drain

GV-HR 120 can produce several litres of condensation water per day. It is therefore important that the condensation outlet is correctly executed and the HRV unit installed horizontally.

Check that the water seal is airtight and firmly in position. The connection must be made so that the user can check and top up the water seal, without opening GV-HR 120.

The condensation outlet is adapted for the type of water seal that is traditionally used for a wash basin (connection G32).

CLEANING THE CONDENSATION WATER DRAIN

Condensation forms when GV-HR 120 is working. This condensation is led off and collected in the condensation water drain. Apart from water, a certain amount of dust and particles also collect there.

Check regularly that the condensation water drain and any floor drains are not blocked; water must be able to run through freely. Clean, if necessary.



NOTE

During operation, negative pressure arises in the HRV unit, which means that a water column of at least 100 mm must be guaranteed in the water seal.

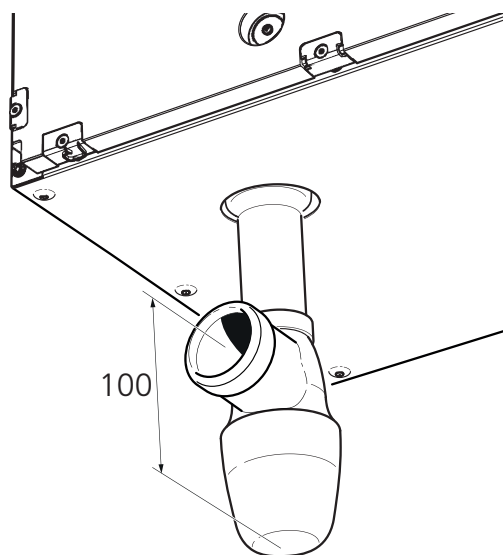

General ventilation connections

- Ventilation installation must be carried out in accordance with current norms and directives.
- Provision must be made for inspection and cleaning of the duct.
- The air duct system must be a minimum of air tightness class B.
- To prevent fan noise being transferred to the ventilation devices, install silencers in suitable locations in the duct system.
- The extract air and outdoor air ducts are insulated using diffusion-proof material (at least PE30 or equivalent) along their entire lengths.
- Ensure that the condensation insulation is fully sealed at any joints and/or at lead-in nipples, silencers, roof cowls or similar.
- The air must be routed to the outdoor air duct through an outer wall grille in the facade. The outer wall grille must be installed so that it is protected from the weather and must be designed so that no rainwater and/or snow can penetrate the facade or follow the air into the duct.
- When positioning the outdoor air and extract air hood/grille, bear in mind that the two air flows must not short circuit to prevent the extract air from being drawn into GV-HR 120 again.
- A duct in a masonry chimney stack must not be used for extract air or outdoor air.



NOTE

To ensure a sealed connection to GV-HR 120, the supplied hose clips must be used for connecting the air ducts.

EXHAUST AIR DUCT /KITCHEN FAN

Exhaust air duct (kitchen fan) must not be connected to GV-HR 120.

To prevent food vapour being transferred to GV-HR 120 the distance between the kitchen fan and the exhaust air device must be considered. The distance should not be less than 1.5 m, but this can vary between different installations.

Always use a kitchen fan when cooking.

Ventilation flow

Connect GV-HR 120 so that all the exhaust air, except kitchen duct air (kitchen fan), passes through the heat exchanger (EP26) in the product.

The ventilation flow must comply with the applicable national standards.

The supply air flow must be lower than the exhaust air flow to prevent over pressure in the house.

Set the ventilation capacity in the HRV unit's menu system (Service menu, menu 10-15).

Adjusting ventilation

To obtain the necessary air exchange in every room of the building, the exhaust air valve and the supply air inlet as well as the fans in the HRV unit must be correctly positioned and adjusted.

Immediately after installation adjust the ventilation so that it is set according to the projected value of the house.

Incorrect adjustment of the ventilation may lead to reduced installation efficiency and thus poorer operating economy, a poorer indoor climate and moisture damage in the building.

Dimensions and ventilation connections

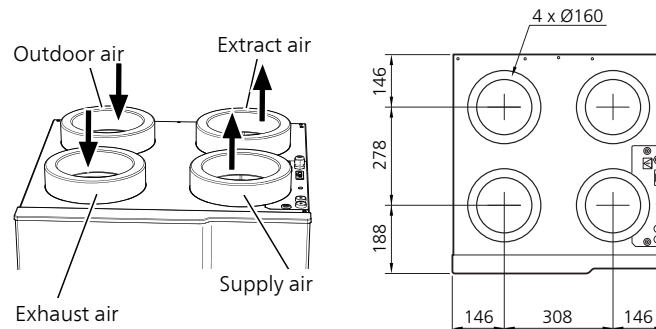

5 Electrical connection



NOTE

All electrical connections must be carried out by an authorised electrician.

Electrical installation and wiring must be carried out in accordance with the stipulations in force.

ERS S10 must not be powered during installation.



NOTE

If the supply cable is damaged, only NIBE, its service representative or similar authorised person may replace it to prevent any danger and damage.

- To prevent interference, sensor cables to external connections must not be laid close to high voltage cables.
- The minimum area of communication and sensor cables to external connections must be 0.5 mm² up to 50 m, for example EKKX, LiYY or equivalent.

For electrical wiring diagram, see page 36.

PCB overview (AA2)

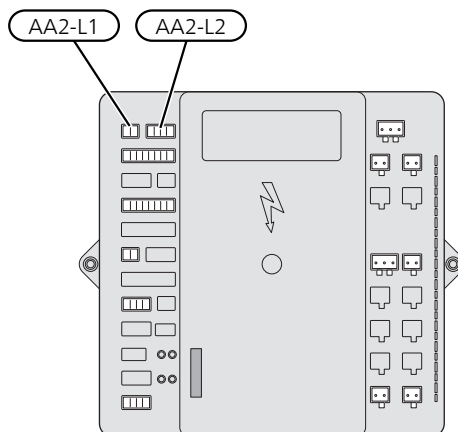

Supply

GV-HR 120 is connected to a earthed single-phase wall socket or a permanent installation. For permanent installations, GV-HR 120 must be preceded by a circuit breaker with at least a 3 mm breaking gap.

Display

GV-HR 120 is supplied with an enclosed display (AA4), which contains a room sensor (BT50). The room sensor is primarily used to control any re-heater, if one is installed.

Install the display in a neutral location where the set temperature is required.

A suitable location is on a free inner wall in a hall approx. 1.5 m above the floor. It is important that the sensor is not prevented from measuring the correct room temperature, for example by being located in a recess, between shelves, behind a curtain, above or close to a heat source, in a draught from an external door or in direct sunlight. Closed radiator thermostats can also cause problems.

The display contains a light sensor (BR2) that regulates its brightness; for this reason, it should not be placed close to a lamp.

1. Fit the display mount on the wall.

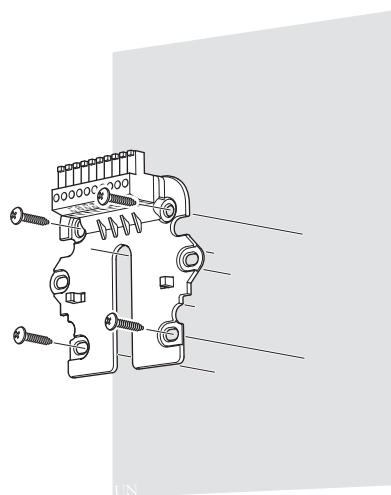

2. Install the display on the mount by connecting the connector and then carefully pressing the lower part of the display against the wall.

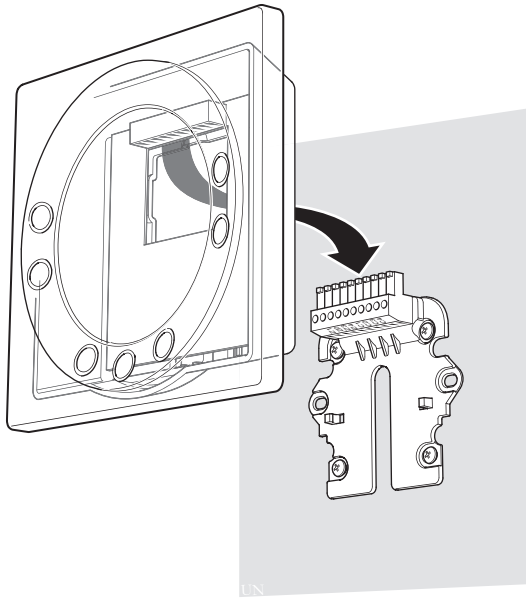

External connection options

A contact (NO) can be connected to AA2-L1:1-2 to activate various fan speeds.

The function is activated during the time the contact is closed. Normal speed is resumed when the contact opens again.

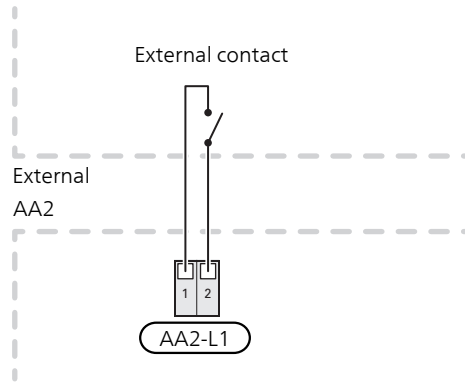

The communication cable to the display is fitted in GV-HR 120 at the factory and connected to terminal block 21-24 in the display. If the cable needs to be extended, use a four core cable with a cable area of at least 0.25 mm² for cable lengths up to 50 m. (max. length).

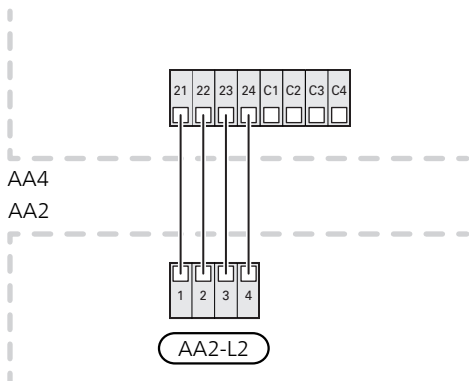

6 Commissioning and adjusting

Preparations

- Check that the air filters are clean, they can become dirty after installation.

Filling

- Check that there is water in the water seal, fill if necessary.

Start-up and inspection

COMMISSIONING

The first time the installation is started, a start guide is launched. In the start guide, you select the language you want in the display.



Caution

As long as the start guide is active, no function in GV-HR 120 will start automatically.

OPERATION IN THE START GUIDE

1. Press the Next button to scroll between the selectable languages.
2. Select language by pressing "←".

After the language has been chosen, GV-HR 120 will enter the appropriate program version in the selected language, which takes approx. 1.5 minutes.

SD CARD

After commissioning GV-HR 120, it is possible to have the installation in operation without an SD card (AA32), but there will then not be any help texts in the display.

SETTING THE VENTILATION

The ventilation must be set according to applicable standards. Adjust the supply air flow to guarantee a negative pressure.

The settings are adjusted in Service menu, menu 10-15.

Even if ventilation is roughly set at installation it is important that a ventilation adjustment is ordered and permitted.



Caution

An incorrectly set ventilation flow can damage the house and may also increase energy consumption.



NOTE

Order a ventilation adjustment to complete the setting.

Ventilation capacity

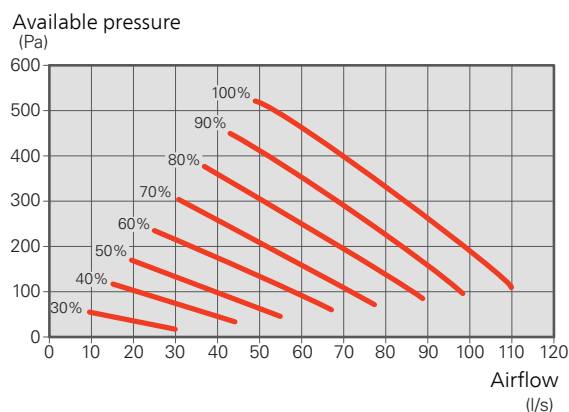

Fan rating¹

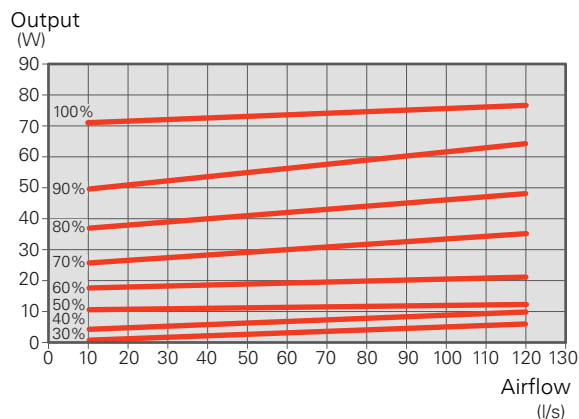

¹The diagram shows the power consumption per fan.

HUMIDITY

GV-HR 120 has a built-in humidity sensor (BM20) that is used when demand-controlled ventilation is required.

The speed of the fans is regulated with respect to a set value depending on the humidity measured in the exhaust air as well as the calculated humidity outdoors, to achieve the desired relative humidity in the home.

The end point for the desired relative humidity in the home is set in Service menu, menu 32 - "Humidity max temp" and menu 33 - "Humidity max value".

Set point value, humidity

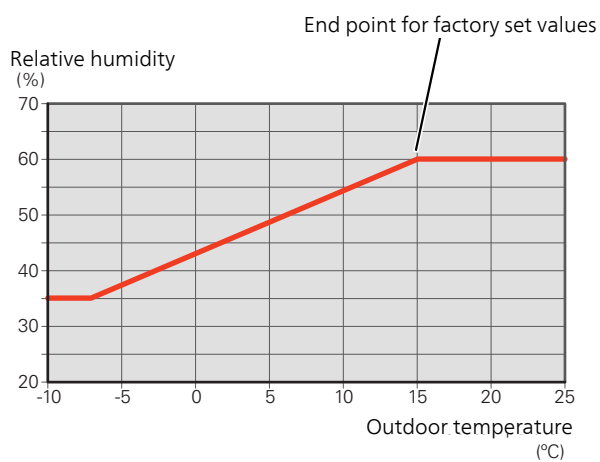

For more information, see page 27.

7 Control - Introduction

Display

Instructions, settings and operating information are shown on the display. You can easily navigate between the different menus and options to set the ventilation or obtain the information you want.

The buttons on the display have various functions depending on whereabouts you are in the menu system.

Operating menu

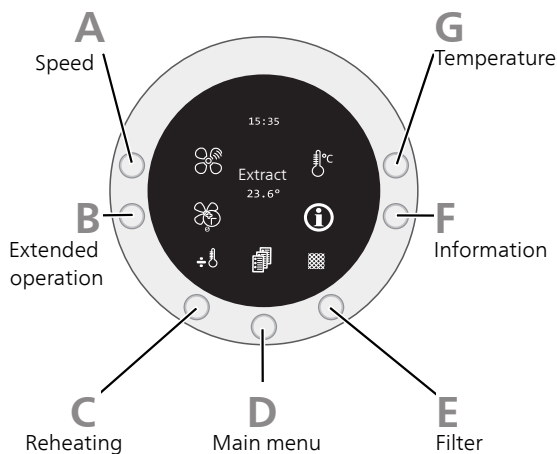

The operating menu contains quick buttons for various functions.

A SPEED

Select the fan speed here (1-4). Switch off the fan by pressing and holding the button for 3-4 seconds.

It is a precondition that Service menu, menu 28 - "Stop the unit", is set to "on".

Speed 1

Reduced fan speed.

This mode is ideal when there is nobody at home.

The speed is set in Service menu, menu 10 - "Level 1 supply air" and menu 13 - "Level 1 exhaust air"

Speed 2

The fan's normal level.

The speed is set in Service menu, menu 11 - "Level 2 supply air" and menu 14 - "Level 2 exhaust air"

Speed 3

Forced fan speed.

This mode is ideal when there are a lot of people in the home.

The speed is set in Service menu, menu 12 - "Level 3 supply air" and menu 15 - "Level 3 exhaust air"

Speed 4

Forced fan speed. The mode is ideal when you want to lower the indoor temperature slightly, e.g. in the summer.

The speed is 100% and cannot be set.

B EXTENDED OPERATION

Here you activate a temporary increase in ventilation.

In the event of a temporary increase in the ventilation requirement, you can select an increase in ventilation for an optional time (1-9 hours) in this menu.

If the number of hours is set between 1 and 9, the speed 3 will automatically connect back to speed 2 after the set number of hours.

Select speed 0 if you want to switch off the function before the set number of hours has been reached.

C REHEATING

Here you start or switch off any re-heater (external component that is not supplied by NIBE).

If the symbol is set to +, the heater will be connected if necessary; if it is set to ÷, it will not be connected, even if there is a need. It is a precondition that User menu, menu 3 - "Reheating", is "on".

D

MAIN MENU

Here you enter the main menu.

E

FILTER

Here you reset filter alarm.

F

INFORMATION

Quick button for menu **Operation info**.

Here you obtain information about the installation's current operating status (current temperatures, fan speed, activated/deactivated functions, alarms, hour counter, etc.). No changes can be made.

G

TEMPERATURE

Here you set the temperature for any re-heater (external component that is not supplied by NIBE).

Main menu

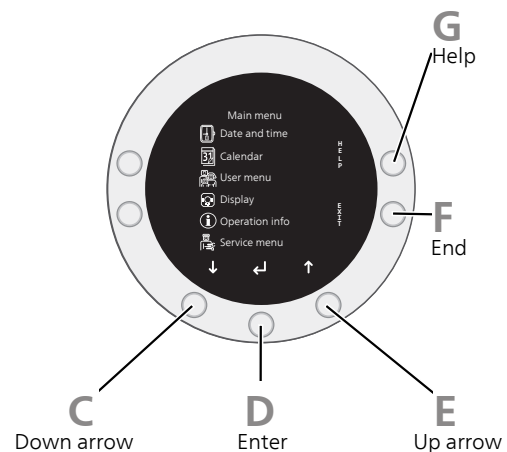

Here, you can find the HRV unit's menu system.

C

DOWN ARROW ↓

Used to:

- scroll in menus and between options.
- decrease the values.

D

ENTER ↵

Used to:

- confirm selections of sub menus/options/set values.

E

UP ARROW ↑

Used to:

- scroll in menus and between options.
- increase the values.

F

EXIT

Used to:

- go back to the previous menu.
- change a setting that has not been confirmed.

G

HELP

Used to:

- obtain a brief description of the current menu.

Menu system

The screensaver is switched off and the operating menu is displayed when you press any of the buttons or move your hand in front of the display.

OPERATION

To continue to the menu system, you press the button for Main menu.

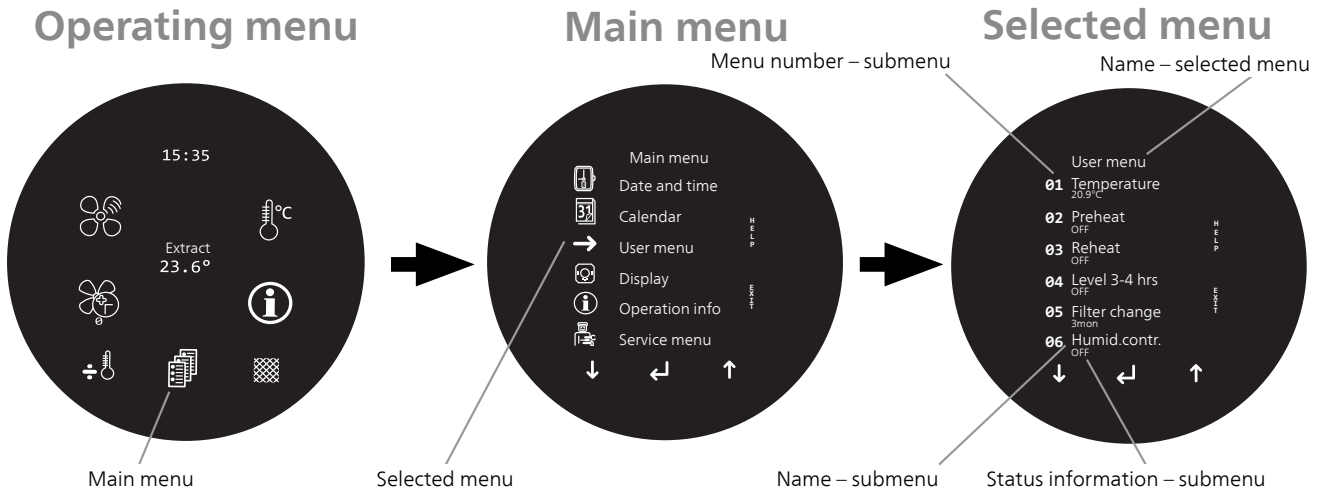

SELECTING MENU

To move the cursor in the main menu and its submenus, press "↑" or "↓". The relevant menu is marked with an arrow.

Select the menu by pressing "↵".

SETTING A VALUE

To set a value:

1. Mark the value you want to change using "↑" or "↓".



2. Press "↵". The background of the value turns grey, which means that you have accessed the setting mode.

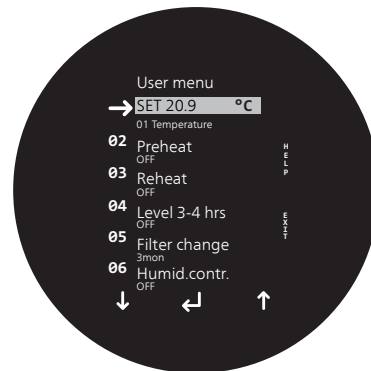

3. Press "↑" or "↓" to increase or decrease the value.

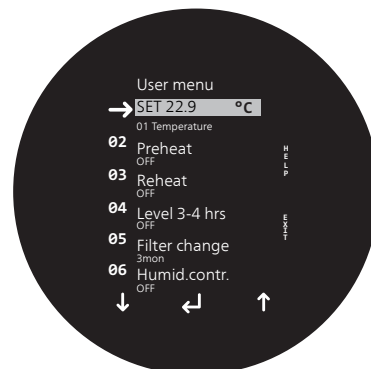

4. Press "↵" to confirm the value you have set. To change your mind and return to the original value, press the Exit button instead.

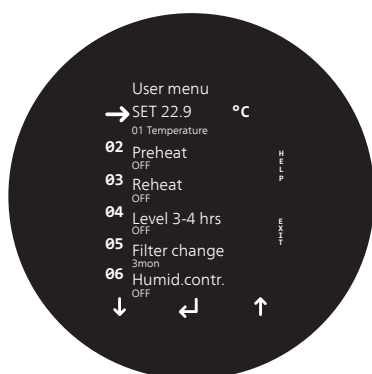

HELP MENU

In many menus there is a symbol that indicates that extra help is available.

To access the help text, press the Help button. To exit help mode, press the Exit button or "↵".

8 Control - Menus

Date and time

OVERVIEW

Date and time	1 - Hours
	2 - Minutes
	3 - Weekday
	4 - Date
	5 - Month
	6 - Year

Calendar

OVERVIEW

Calendar	1 - Calendar
	2 - Monday
	3 - Tuesday
	4 - Wednesday
	5 - Thursday
	6 - Friday
	7 - Saturday
	8 - Sunday
	9 - Copy day

User menu

OVERVIEW

User menu	1 - Temperature
	2 - Preheating ¹
	3 - Reheating ²
	4 - Level 3-4 hours
	5 - Filter replacement
	6 - Humidity control

¹ Accessory needed.

² External component that is not supplied by NIBE.

Display

OVERVIEW

Display	1 - Language
	2 - Program info
	3 - Screensaver
	4 - Pause time
	5 - Auto advance
	6 - Auto brightness
	7 - Brightness, day
	8 - Brightness, night
	9 - Screensaver light, day
	10 - Screensaver light, night
	11 - Factory setting
	12 - Safety menu
	13 - Date and time
	14 - Calendar
	15 - User menu
	16 - Display
	17 - Service menu
	18 - Password

Operation info

OVERVIEW

Operation info	1 - Temperatures
	2 - Fans
	3 - Functions
	4 - Alarm
	5 - Hour counter

Service menu

OVERVIEW

Service menu	10 - Level 1 supply air
	11 - Level 2 supply air
	12 - Level 3 supply air
	13 - Level 1 exhaust air
	14 - Level 2 exhaust air
	15 - Level 3 exhaust air
	16 - T2 adjustment
	17 - Level 3 - 4 h
	18 - Filter/stop
	19 - Room/on/off
	20 - Preheating
	21 - Bypass max.
	22 - Water control ¹
	23 - Power regulator
	24 - Frost reduction
	25 - Frost ¹
	26 - Frost ¹
	27 - Auxiliary relay R9
	28 - Stop the unit
	29 - Interrupt bypass t3
	30 - Modbus mode
	31 - Modbus address
	32 - Humidity max. temp.
	33 - Humidity max. value
	34 - Humidity ventilation speed
	35 - Humidity control frequency
	36 -
	37 - Air heater PI P
	38 - Air heater PI I
	39 - Preheating cycle
	40 - Reheating set ¹
	41 - Re-heater PI P ¹
	42 - Re-heater PI I ¹
	43 - Reheating control ¹
	44 - Demand control
	45 - Fire damper

¹External component that is not supplied by NIBE.

Sub-menus

Service menu is intended for advanced users. This menu has several submenus. Under the menus on the display, there is status information for each menu.

MENU 10 - LEVEL 1 SUPPLY AIR

Setting range: 0 - 100%
Factory setting: 30%

Here you set the speed for the supply air fan's lowest level.

This mode is ideal when there is nobody at home.

MENU 11 - LEVEL 2 SUPPLY AIR

Setting range: 0 - 100%
Factory setting: 50%

Here you set the speed for the supply air fan's normal level.

MENU 12 - LEVEL 3 SUPPLY AIR

Setting range: 0 - 100%
Factory setting: 75%

Here you set the speed for the supply air fan's highest level.

This mode is ideal when there are a lot of people in the home.

MENU 13 - LEVEL 1 EXHAUST AIR

Setting range: 0 - 100%
Factory setting: 30%

Here you set the speed for the exhaust air fan's lowest level.

This mode is ideal when there is nobody at home.

MENU 14 - LEVEL 2 EXHAUST AIR

Setting range: 0 - 100%
Factory setting: 50%

Here you set the speed for the exhaust air fan's normal level.

MENU 15 - LEVEL 3 EXHAUST AIR

Setting range: 0 - 100%
Factory setting: 75%

Here you set the speed for the exhaust air fan's highest level.

This mode is ideal when there are a lot of people in the home.

MENU 16 - T2 ADJUSTMENT

Setting range: -5 - 0 °C
Default value: -3 °C

You adjust the display's built-in room sensor (BT50) here so that it displays the correct temperature

MENU 17 - LEVEL 3-4 T

Setting range: 1 - 9 h
Factory setting: 3 h

Select the return time for temporary speed change (speed 3) of the ventilation in User menu, menu 4 - "Level 3-4 hours".

Return time is the time taken before the ventilation speed returns to level 2.

MENU 18 - FILTER/STOP

Setting range: "On" and "off"
Factory setting: "On"

If you select "on", the filters must be replaced within 14 days after a filter alarm, otherwise GV-HR 120 will stop.

If you select "off", GV-HR 120 will continue to work, even though the filters are soiled.

MENU 19 - ROOM/ON/OFF

Setting range: 0 - 2
Default value: 1

Here you select control of GV-HR 120:

- 0 Room control/room sensor (BT50)
- 1 Supply air control/supply air sensor (BT22)
- 2 Exhaust air control/exhaust air sensor (BT20)

A re-heater is required in order to heat the home with GV-HR 120 and control the installation with supply air or exhaust air control. In installations that do not have reheating, GV-HR 120 is only used to ventilate the home and to utilise the energy in the extract air. In this type of installation, supply air control is recommended.

MENU 20 - PREHEATING

Setting range: -15 - 10 °C
Default value: -3 °C

Here you set the outdoor air temperature at which the electrical air heater (EAH 21) will start.



TIP

Select -3°C if you want to prevent ice forming.

MENU 21 - BYPASS MAX

Setting range: 1 - 10 °C

Default value: 3 °C

Here you set control of the bypass damper.

The damper opens when the temperature is 1°C above the set value in User menu, menu 1 - "Temperature", provided that

- the exhaust air temperature is higher than the outdoor air temperature
- the outdoor air temperature is above the set value in Service menu, menu 29 - "Stop bypass t3".



TIP

In order to achieve even control, the temperature at fully open damper should be approx. 3°C above the set temperature in User menu, menu 1 - "Temperature".

MENU 22 - WATER CONTROL

Setting range: 1 - 250 sec.

Factory setting: 20 sec.

Here you set the control of the waterborne re-heater with a motor valve. The lower the value, the faster the valve will exercise control.

MENU 23 - POWER REGULATOR

Setting range: 1 - 30 min

Factory setting: 3 min

Here you set the control of the electrical air heater (EAH 21) or re-heater. The lower the value, the faster the valve will exercise control.

MENU 24 - FROST REDUCTION

Setting range: 0 - 10 °C

Default value: 3 °C

Here you set the extract air temperature at which the supply air flow will be reduced to prevent damage to the heat exchanger (EP26) due to freezing.

The supply air flow is gradually reduced until the set value is reached. This function is only active if the set value is greater than 0°C.



NOTE

Can cause negative pressure in the house.

MENU 25 - FROST

Setting range: "On" and "off"

Factory setting: "Off"

Waterborne re-heater with motor valve required.

Select "on" if the re-heater has a frost sensor.



TIP

Should the re-heater have a frost sensor in order to avoid damage? In order for the installation to work? In order...

MENU 26 - FROST

Setting range: 0 - 10 °C

Default value: 5 °C

Waterborne re-heater with motor valve required.

Here you set the temperature at which the waterborne re-heater will defrost.

MENU 27 - AUXILIARY RELAY R9

Setting range: 0 - 5

Default value: 0

Here, you can force control the various components in the HRV unit.



NOTE

Forced control is only intended to be used for troubleshooting purposes. Using the function in any other way may cause damage to the components in the installation.

- 0 The relay is switched off.
- 1 The relay is engaged, provided the installation is in use. The relay can be used, for example, to open or close the supply air or exhaust air damper.
- 2 The relay is engaged when there is a need for additional heat or when there is a wish to operate the circulation pump, when heating with waterborne reheating is required.
- 3 The relay is engaged on filter alarm. This can be used to activate an external alarm.
- 4 The relay is engaged when there is a need for extra cooling. This function is used if the installation has an electrical air heater (EAH 21) installed.

- 5 The control can manage an earth heat exchanger with a damper. The relay is engaged in one of the two following circumstances:
- The outdoor temperature, sensor T9, is lower than the set value in Service menu, menu 26 - "Frost".
 - The outdoor temperature, sensor T9, is more than 1°C above the set temperature in Service menu, menu 10 - "Level 1 supply air" and 1°C above current room temperature.

MENU 28 - STOP THE UNIT

Setting range: "On" and "off"
 Factory setting: "Off"

The installation can be switched off by pressing and holding the "Speed" button for 4 seconds.

Select "on" to activate the function.

MENU 29 - INTERRUPT BYPASS T3

Setting range: 0 - 20 °C
 Default value: 4 °C

Here you set the outdoor air temperature at which the bypass damper (QN37) will be closed, to prevent cold air from being blown into the home.

This value is an expression of the largest permitted difference between the desired temperature set in User menu, menu 1 - "Temperature", and the lowest permitted supply air temperature.



NOTE

Incorrect settings in this menu may damage the installation.

MENU 30 - MODBUS MODE

Setting range: 0 - 2
 Default value: 0

- 0 Modbus switched off
- 1 9600 Baud
- 2 19200 Baud



NOTE

Incorrect settings for Modbus may damage the installation.

MENU 31 - MODBUS ADDRESS

Setting range: 1 - 247
 Default value: 1

Set the address here.

See the accessory installation instructions for function description.

MENU 32 - HUMIDITY, MAX. TEMP.

Setting range: 5 - 25 °C
 Default value: 15 °C

Here you set the end point for outdoor temperature compensation (T3), see the x-axis in the diagram "Set point value, humidity" on page 17.

MENU 33 - HUMIDITY, MAX. VALUE

Setting range: 35 - 85%
 Factory setting: 60%

Here you set the end point for outdoor temperature compensation (T3), see the y-axis in the diagram "Set point value, humidity" on page 17.

MENU 34 - HUMIDITY, VENTILATION SPEED

Setting range: 5 - 30%
 Factory setting: 15%

Here you set the amount by which the fan speed may deviate in relation to the desired fan setting.

The factory setting of 15% means that the fan speed may be 15% higher or lower than the set value in menu Service menu, menu 11 - "Level 2 supply air", 12 - "Level 3 supply air", 14 - "Level 2 exhaust air" and 15 - "Level 3 exhaust air".

MENU 35 - HUMIDITY, CONTROL FREQUENCY

Setting range: 1 - 60 min.
 Factory setting: 10 min

Here you set the desired frequency for how often the fan speed may be changed. The adjustment is made at 1% for each time unit, e.g. for every 10 minutes.

MENU 36 -

Not used.

MENU 37 - AIR HEATER PI P

Setting range: 1 - 255
 Default value: 5

The electrical air heater (EAH 21) is controlled with PI control.

In this menu, you set the desired amplification (the P section).

MENU 38 - AIR HEATER PI I

Setting range: 1 - 255
Default value: 5

The electrical air heater (EAH 21) is controlled with PI control.

In this menu, you set the desired time (the I time).

MENU 39 - PREHEATING CYCLE

Setting range: 10 - 120 sec.
Factory setting: 40 sec.

Here you set the electrical air heater's (EAH 21) work cycle.

If the power is 50% and the setting in this menu is 60 seconds, the heater will be in operation for 30 seconds and switched off for 30.



Caution

The setting must comply with any national standards.

The modulating air heater function is controlled by the value set in Service menu, menu 20 - "Preheating".

The air heater tries to maintain a constant supply air temperature in accordance with this setting.

No additional sensor is required, as the existing outdoor air sensor (BT23) is used.

MENU 40 - REHEATING SET

Setting range: -10.0 - 10.0 °C
Default value: 2.0 °C

In User menu, menu 1 - "Temperature", you set the desired temperature; in this menu you set the desired offset value.

If the desired temperature is 20°C and the offset value is 2, the re-heater will try to maintain 18°C as the supply air temperature.

MENU 41 - RE-HEATER PI P

Setting range: 1 - 255
Default value: 5

For electrical re-heaters that can be controlled with PI control.

In this menu, you set the desired amplification (the P section).

MENU 42 - RE-HEATER PI I

Setting range: 1 - 255
Default value: 200

For electrical re-heaters that can be controlled with PI control.

In this menu, you set the desired time (I time).

MENU 43 - REHEATING CONTROL

Setting range: 10 - 120 sec.
Factory setting: 40 sec.

Here you set the electrical re-heater's work cycle, if applicable.

If the power is 50% and the setting in this menu is 60 seconds, the heater will be in operation for 30 seconds and switched off for 30.



Caution

The setting must comply with any national standards.

The modulating re-heater function is controlled by the value set in Service menu, menu 40 - "Reheating set".

The re-heater tries to maintain a constant supply air temperature in accordance with this setting.

The existing supply air sensor (BT22) is replaced with a sensor that is placed in the ventilation duct after the heater.

MENU 44 - DEMAND CONTROL

Setting range: 0 - 100 %
Factory setting: 0 sec.

MENU 45 - FIRE DAMPER

Setting range: 0 - 4
Default value: 0

9 Disturbances in comfort

In most cases, GV-HR 120 detects a malfunction (malfunctions can lead to disruptions in comfort) and indicates this with an alarm in the display.

Info-menu

All the installation's measurement values are available from the menu Operation info in the display. Examining the values in this menu can often make it easier to identify the source of the fault. See help menu or user manual for more information about menu Operation info.

Manage alarm

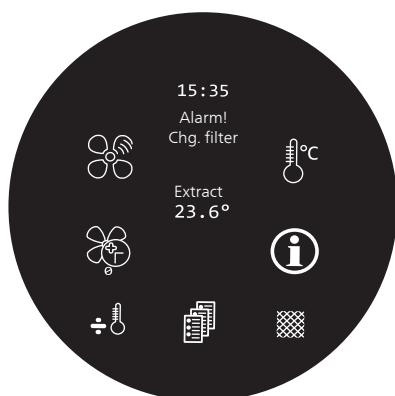

If there is an alarm, some kind of malfunction has occurred, which is shown by text in the display.

ALARM

If there is an alarm, a malfunction has occurred that GV-HR 120 cannot rectify itself. The display shows what type of alarm it is.

Error message	Significance
Control stopped	*Filter not replaced within 14 days. *Frost protection fault. *External alarm activated.
Change the filter	*The filters need to be changed.
Frost protection	*The temperature of the waterborne re-heater is too low.
Comm. fault	*Communication fault between the PCB (AA2) and the display (AA4).

Troubleshooting

If the operational interference is not shown in the display the following tips can be used:

BASIC ACTIONS

Start by checking the following items:

- That the feed cable is connected to GV-HR 120.
- That the display cable is connected to GV-HR 120.
- Group and main fuses of the accommodation.
- The property's earth circuit breaker.
- Temperature limiter in electrical air heater (EAH 21).

LOW OR A LACK OF VENTILATION

- Filters (HQ10), (HQ11) blocked.
 - Replace the filters.
- The ventilation is not adjusted.
 - Order/implement ventilation adjustment.
- Closed, too much choke or blocked ventilation device.
 - Check and clean the ventilation devices.
- Fan speed in reduced mode.
 - Check the setting for "Speed" in the Operating menu.
- External switch for changing the fan speed activated.
 - Check any external switches.
- Fan running slow because of low incoming outdoor air temperature.
 - Check the function and settings for the electrical air heater (EAH 21) if installed.

HIGH OR DISTRACTING VENTILATION

- Filters (HQ10), (HQ11) blocked.
 - Replace the filters.
- The ventilation is not adjusted.
 - Order/implement ventilation adjustment.
- Closed, too much choke or blocked ventilation device.
 - Check and clean the exhaust air devices.
- Fan speed in forced mode.
 - Check the setting for "Speed" in the Operating menu.
 - Check the setting for "Extended operation" in the Operating menu.
 - Check User menu, menu 4 - "Level 3-4 hour" and select "off" to return automatically to level 2.
- External switch for changing the fan speed activated.

- Check any external switches.
- Silencers not correctly installed.
 - Check the silencers.

10 Service

Service actions

USB SERVICE OUTLET

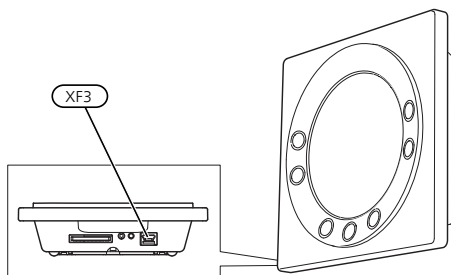

The display is equipped with a mini-USB socket (XF3) that can be used to update the software and log information.

Logging

If you want to see the installation's operating licence, connect the display to a computer. You will need a data logging program in order to analyse the information.

11 Accessories

Detailed information about the accessories and complete accessories list available at nibe.eu.

Not all accessories are available on all markets.

ELECTRICAL AIR HEATER EAH 21

In cold weather, EAH heats the incoming outdoor air slightly to prevent the condensation in GV-HR 120 from freezing to form ice. EAH should be used in houses where the outdoor temperature can be continuously lower than -5°C.

EAH 21-1800

(300-1800 W)

Part no. 067 605

TOP CABINET TOC 40

Top cabinet that conceals the ventilation ducts and reduces the sound to the installation room.

Height 245 mm

Height 345 mm

Part no. 089 756

Part no. 089 757

Height 445 mm

Height 385 - 635 mm

Part no. 067 522

Part no. 089 758

12 Technical data

Dimensions

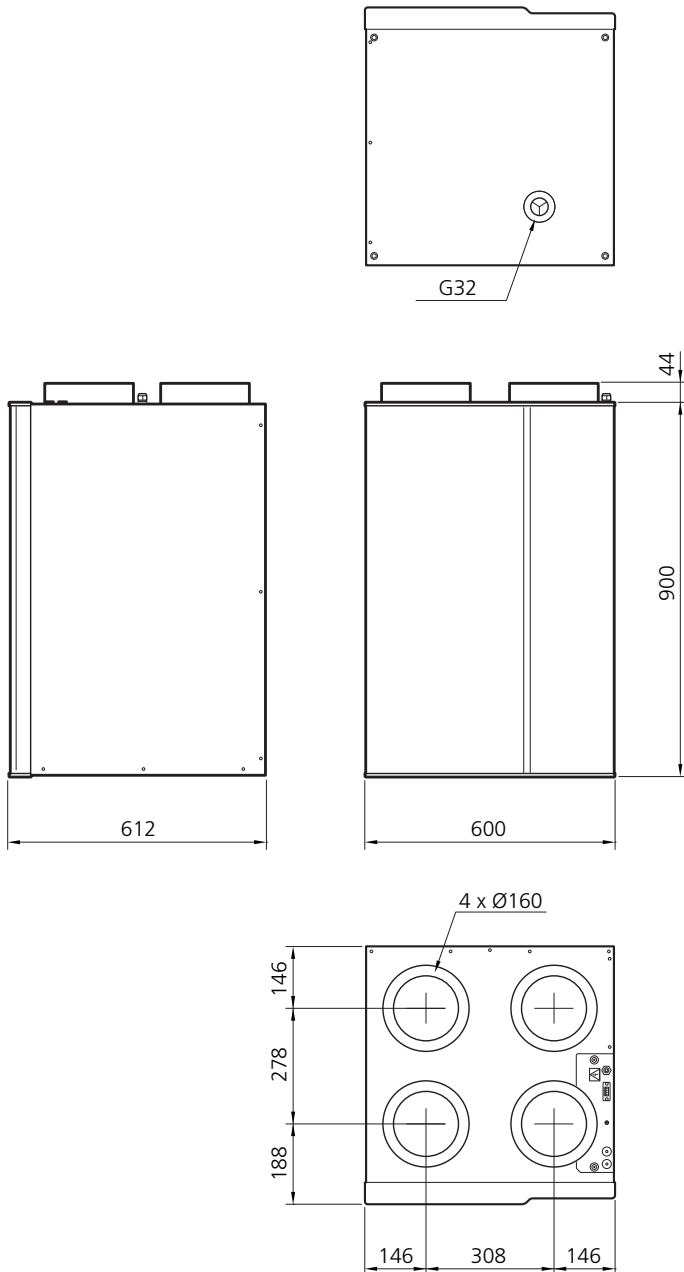

Technical specifications

Type		GV-HR 120
<i>Electrical data</i>		
Supply voltage	V	230 V ~ 50Hz
Fuse	A	10
Driving power fan	W	2 x 85
Enclosure class		IP X1B
<i>Ventilation</i>		
Filter type, exhaust air filter		Coarse 65%
Filter type, supply air filter		ePM1 55%
<i>Noise</i>		
Sound power level ($L_{W(A)}$) ¹	dB(A)	47
Sound pressure level ($L_{P(A)}$) at 1 m ²	dB(A)	45
<i>Pipe connections</i>		
Ventilation Ø	mm	160
Condensation water drain		G32
<i>Dimensions and weight</i>		
Efficiency class ³		A
Length, supply cable	m	2.4
Length, communication cable	m	2.0
Width	mm	600
Height	mm	900
Depth	mm	612
Weight	kg	40
Part No.		066 118

1 277 m³/h (77 l/s) at 50 Pa

2 230 m³/h (64 l/s) at 50 Pa

3 Scale for efficiency class: A+ to G.

Dry temperature efficiency according to EN 308

Temperature efficiency

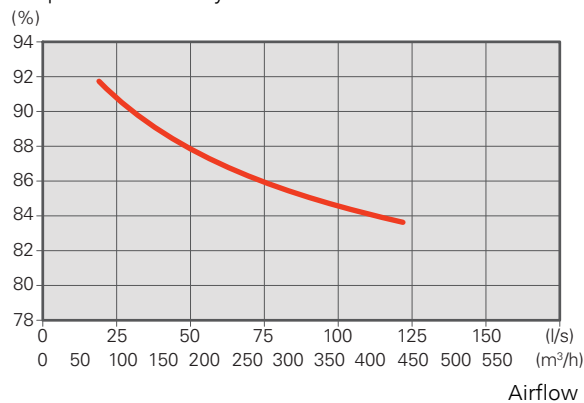

Outdoor air: 5 °C Exhaust air 25 °C RH exhaust air: <27.7 %

Energy labelling

Supplier		NIBE
Model		GV-HR 120
Specific energy consumption (SEC)	kWh/(m ² year)	Average: -39.4 Cold: -77.3 Warm: -15.0
Energy efficiency class		A
Declared typology		RVU, Bidirectional
Type of drive		Variable speed drive
Type of heat recovery system		Recuperative
Thermal efficiency of heat recovery		86
Maximum air flow rate	m ³ /h	394
Electric power input of the fan drive at maximum flow rate	W	163
Sound power level (LWA)	dB	47
Reference flow rate	m ³ /s	0.077
Reference pressure difference	Pa	50
Specific power input (SPI)	W/m ³ /h	0.242
Control factor and control typology		Clock control (0.85)
External leakage rates	%	Intern: 2.0 Extern: 1.6
Information about filter warning		See user manual.
Information about supply/exhaust grilles in the facade		See section General ventilation connections on page 13.
Information about pre-/disassembly		See section Recovery on page 5. This installer manual can also be accessed at nibe.eu.
The annual electricity consumption	kWh/year	263
Annual heating saved, kWh primary energy per year	kWh prim/year	Average: 4,527 Cold: 8,856 Warm: 2,047

ELECTRICAL CIRCUIT DIAGRAM

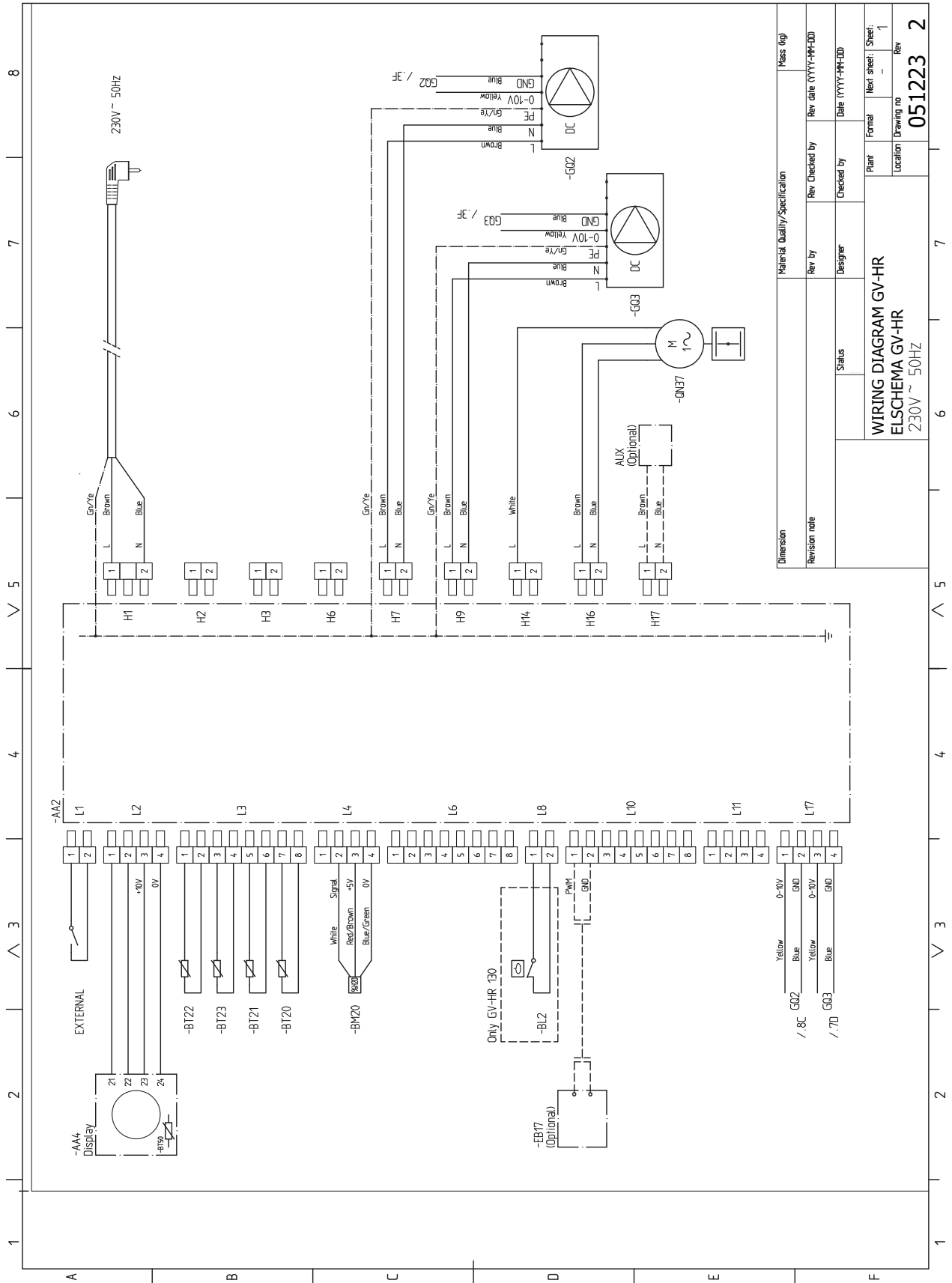

Dimension	Material Quality/Specification	Mass (kg)
Revision note	Rev. By	Rev. Checked by
	Designer	Date: (YYYY-MM-DD)
	Status	Rev. Date: (YYYY-MM-DD)
WIRING DIAGRAM GV-HR ELSCHEMA GV-HR 230V ~ 50HZ		
Plant	Formal	Next sheet / Sheet:
Location	Drawing no	Rev
	051223	2

Item register

A

Accessories, 32
Adjusting ventilation, 13
Assembly, 8

B

Button, extended operation, 18
Button, filter, 19
Button, information, 19
Button, main menu, 19
Button, reheating, 18–19
Button, temperature, 19

C

Commissioning and adjusting, 16
 Filling and venting, 16
 Preparations, 16
Condensation outlet, 12
 Cleaning, 12
Control - Menus
 Service menu, 24

D

Delivery and handling, 7
 Assembly, 8
 Installation, 9
 Removing parts of the insulation, 7
 Removing the covers, 7
 Supplied components, 7
 Transport and storage, 7
Design of the HRV unit, 10
Dimensions and ventilation connections, 13
Display, 18
Display unit
 Button, extended operation, 18
 Button, filter, 19
 Button, information, 19
 Button, main menu, 19
 Button, reheating, 18–19
 Button, temperature, 19
 Display, 18
 Speed button, 18
Disturbances in comfort, 29
 Troubleshooting, 30

E

Electrical circuit diagram, 36
Electrical connection, 14
Energy labelling, 35
Exhaust air duct, 13

F

Filling and venting, 16

G

General ventilation connections, 13

I

Important information, 4
 Recycling, 5
Inspection of the installation, 6
Installation area, 8

M

Marking, 4
Mounting, 9

P

Pipe and ventilation connections
 Exhaust air duct, 13

R

Recycling, 5
Removing parts of the insulation, 7
Removing the covers, 7

S

Safety information
 Inspection of the installation, 6
 Marking, 4
 Symbols, 4
Serial number, 4
Service actions
 USB service outlet, 31
Service menu, 24
Speed button, 18
Start-up and inspection
 Setting the ventilation, 16
Supplied components, 7
Symbols, 4

T

Technical data
 Electrical circuit diagram, 36
The design of the exhaust air module
 List of components, 11
Transport and storage, 7
Troubleshooting, 30

U

USB service outlet, 31

v

Ventilation connections, 12

Adjusting ventilation, 13

Condensation outlet, 12

Dimensions and ventilation connections, 13

General ventilation connections, 13

Ventilation flows, 13

Ventilation flow, 13

Contact information

AUSTRIA

KNV Energietechnik GmbH
Gahberggasse 11, 4861 Schörfling
Tel: +43 (0)7662 8963-0
mail@knv.at
knv.at

CZECH REPUBLIC

Družstevní závody Dražice - strojírna
s.r.o.
Dražice 69, 29471 Benátky n. Jiz.
Tel: +420 326 373 801
nibe@nibe.cz
nibe.cz

DENMARK

Vølund Varmeteknik A/S
Industrivej Nord 7B, 7400 Herning
Tel: +45 97 17 20 33
info@volundvt.dk
volundvt.dk

FINLAND

NIBE Energy Systems Oy
Juurakkotie 3, 01510 Vantaa
Tel: +358 (0)9 274 6970
info@nibe.fi
nibe.fi

FRANCE

NIBE Energy Systems France SAS
Zone industrielle RD 28
Rue du Pou du Ciel, 01600 Reyrieux
Tél: 04 74 00 92 92
info@nibe.fr
nibe.fr

GERMANY

NIBE Systemtechnik GmbH
Am Reiherpfahl 3, 29223 Celle
Tel: +49 (0)5141 75 46 -0
info@nibe.de
nibe.de

GREAT BRITAIN

NIBE Energy Systems Ltd
3C Broom Business Park,
Bridge Way, S41 9QG Chesterfield
Tel: +44 (0)845 095 1200
info@nibe.co.uk
nibe.co.uk

NETHERLANDS

NIBE Energietechnik B.V.
Energieweg 31, 4906 CG Oosterhout
Tel: +31 (0)168 47 77 22
info@nibenl.nl
nibenl.nl

NORWAY

ABK-Qviller AS
Brobekkveien 80, 0582 Oslo
Tel: (+47) 23 17 05 20
post@abkqviller.no
nibe.no

POLAND

NIBE-BIAWAR Sp. z o.o.
Al. Jana Pawla II 57, 15-703 Bialystok
Tel: +48 (0)85 66 28 490
biawar.com.pl

RUSSIA

EVAN
bld. 8, Yuliusa Fuchika str.
603024 Nizhny Novgorod
Tel: +7 831 288 85 55
info@evan.ru
nibe-evan.ru

SWEDEN

NIBE Energy Systems
Box 14
Hannabadsvägen 5, 285 21 Markaryd
Tel: +46 (0)433-27 3000
info@nibe.se
nibe.se

SWITZERLAND

NIBE Wärmetechnik c/o ait Schweiz
AG
Industriepark, CH-6246 Altishofen
Tel. +41 (0)58 252 21 00
info@nibe.ch
nibe.ch

For countries not mentioned in this list, contact NIBE Sweden or check nibe.eu for more information.

NIBE Energy Systems
Hannabadsvägen 5
Box 14
SE-285 21 Markaryd
info@nibe.se
nibe.eu

IHB EN 2110-2 531842

This manual is a publication from NIBE Energy Systems. All product illustrations, facts and data are based on the available information at the time of the publication's approval. NIBE Energy Systems makes reservations for any factual or printing errors in this manual.

©2021 NIBE ENERGY SYSTEMS

